



ASTON MARTIN

Cygnus

Aston Martin Owner's Club

An invitation to join the Aston Martin Owner's Club

The sporting spirit of the 1930s exists today in one of the world's most exclusive car clubs. Enthusiasts in nearly 60 countries are united by an interest in iconic cars with an enviable pedigree. Enjoy the company of like-minded owners in a wide range of activities: social evenings, weekends away or motoring tours. Something more competitive? AMOC Concours are a benchmark for connoisseurs of fine motorcars. A need for speed? We organise track days, sprints and hill climbs as well as circuit racing in venues such as Silverstone, Goodwood and Lime Rock in the USA.



Mirroring Club activity, the Aston Martin Heritage Trust is an educational charity dedicated to the history of the marque from the earliest days almost a century ago. It shares the magnificent 15thC Oxfordshire barn which is the international headquarters, museum and archive. Why not log onto our website to discover more about these unique organisations, and enjoy a hearty welcome from us all.



The Aston Martin Owners Club
Drayton St. Leonard,
Wallingford,
Oxford,
England,
OX10 7BG

Telephone: +44 (0) 1865 400 400

Facsimile: +44 (0) 1865 400 200

E-Mail: hqstaff@amoc.org

Website: www.amoc.org

Introduction	1
Vehicle Security	2
Before Driving.....	3
Controls	4
Driving.....	5
Climate Control.....	6
Audio.....	7
Hands-Free Phone	8
Satellite Navigation	9
Maintenance	10
Specifications	11
Service	A
Aston Martin Assistance.....	B
Aston Martin Warranty	C
Alphabetical Index	D

Every effort has been made to make sure that the information provided in this Owner's Guide is accurate and up-to-date. However neither the manufacturer or the Dealer, by whom this Owner's Guide is supplied, will in any circumstances be held responsible for any inaccuracy or the consequences thereof. All rights reserved.

No part of this publication may be reproduced, stored in a retrieval system or transmitted, in any form, electronic, mechanical, photocopying, recording or other means without prior written permission from Aston Martin Lagonda Limited.

The manufacturer reserves the right to vary specifications without notice in accordance with its policy of continual product improvement.

Produced by the Technical Publications Department
ASTON MARTIN LAGONDA LIMITED
Banbury Road
Gaydon
WARWICK
Warwickshire
CV35 0DB
England
Telephone: (+44) 01926 644300
Fax: (+44) 01926 644733

Introduction

Welcome	1.2
Warnings, Cautions and Notes	1.3
Component Location	1.4
Vehicle Identification	1.4
Data Recording	1.5
Reporting Safety Defects	1.5
Vehicle Provenance.....	1.6



Welcome

Welcome to your new Aston Martin Cygnet.

This Owner's Guide, along with other publications included in your literature pack, provides information which will enhance your pleasure from owning and driving your Aston Martin.

This Owner's Guide has been designed to explain the vehicle's operation and to make the control of its systems easy to understand and operate. All new owners are recommended to carefully study the contents of this Owner's Guide prior to driving.

This Owner's Guide forms part of the essential vehicle equipment for homologation purposes and must stay with the vehicle at all times.

Aston Martin Franchise Dealers

A full list of Aston Martin Dealers worldwide, where sales and service are provided by companies with the facilities, knowledge and factory trained personnel can be found at:

www.astonmartin.com

Every effort is made to make sure that the information given in the dealer list is accurate and up-to-date. However changes amongst holders of the Aston Martin franchise can occur. Neither Aston Martin nor any listed Importer or Dealer shall in any circumstances be held liable for any inaccuracy, or the consequences thereof.

Dealers listed all aim to conform to Aston Martin standards of excellence in both sales and service. However, all vehicles sold as Aston Martins are required to meet local legislation requirements.

Should service be required in a country other than that in which this vehicle was originally purchased, every effort will be made to meet the owner's requirements, but the availability of certain parts may be affected by differences in vehicle and component specifications.

If the nearest Aston Martin Dealer is unable to help, contact Aston Martin directly:

Aston Martin Lagonda Limited

Banbury Road,

Gaydon,

WARWICK,

CV35 0DB

Telephone: (+44) (0)1926 644300

Facsimile: (+44) (0)1926 644733

Aston Martin Dealers are independent traders, they are not the Company's Agents, and therefore have no authority to bind the Company or to enter into any financial or other commitments on the Company's behalf.

Only Aston Martin Dealers are authorised to carry out warranty work.

Aston Martin Authorised Body Repairers

A full list of Aston Martin Authorised Body Repairers worldwide can be found at:

www.astonmartin.com

All Aston Martin Approved Body Repair centres have been assessed and audited to Aston Martin Body Repair Centre standards in either Category A or B.

Category A - Repairs to the bonded aluminium structure and all paint related and light structural damage.

Category B - All paint related and light structural damage.

Every effort is made to make sure that the information given in the Aston Martin Authorised Body Repairers list is accurate and up-to-date. However changes can occur. Neither Aston Martin nor any Aston Martin Authorised Body Repairer shall in any circumstances be held liable for any inaccuracy, or the consequences thereof.

Aston Martin Authorised Service Centres

A full list of Aston Martin Authorised Service Centres can be found at:
www.astonmartin.com

All Aston Martin Approved Service Centres have been assessed and audited to Aston Martin standards.

Every effort is made to make sure that the information given in the Aston Martin Authorised Service Centres list is accurate and up-to-date. However changes can occur. Neither Aston Martin nor any Aston Martin Authorised Service Centre shall in any circumstances be held liable for any inaccuracy, or the consequences thereof.

Warnings, Cautions and Notes

The following Warnings, Cautions and Notes are used within this Owner's Guide to call your attention to specific types of information.

Warnings

 **Warning: Provided to show procedures which must be followed precisely to help avoid the risk of personal injury.**

Cautions

 **Provided to show procedures which must be followed precisely to reduce the possibility of damage to your vehicle.**

Notes

 *Provided to show procedures which will help to avoid difficulties in the operation of your vehicle.*

Component Location

All directions for locating components are described as viewed from the driver's seat, i.e. the fuel filler flap shown on this diagram will be described as 'located at the rear left side of the vehicle'.



Vehicle Identification

The Vehicle Identification Number (VIN) is stamped into the floor pan under the right-hand front seat.

 *To view the VIN, lift the carpet up as shown.*

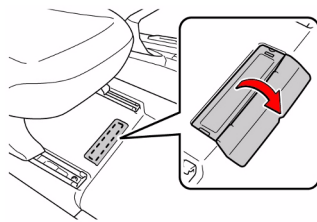

The vehicle is marked with a first stage manufacturer's VIN label (2). Aston Martin Lagonda, as the second stage manufacturer, has added their own manufacturer's VIN label (1). This vehicle has and should be registered using the Aston Martin Lagonda VIN.

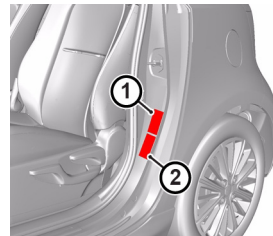

The engine number is stamped on the engine block.

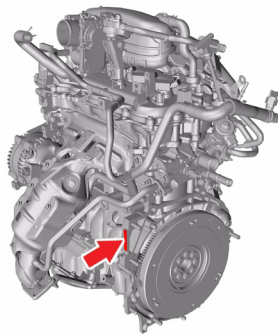

Data Recording

Computers in your vehicle are capable of recording detailed data, potentially including but not limited to information such as:

- The use of restraint systems including seat belts by the driver and passengers
- Information about the performance of various systems and modules in the vehicle
- Information related to engine, throttle, steering, brake or other system status

Any of this information could potentially include information regarding how the driver operates the vehicle, potentially including but not limited to information regarding vehicle speed, brake, throttle application or steering input. This information may be stored under regular operation, in a crash or near crash event.

This information may be read out and used by:

- Aston Martin
- Service and repair facilities
- Law enforcement or government agencies
- Others who may assert a right or obtain your consent to know such information

Reporting Safety Defects

If you believe that your vehicle has a safety defect which could cause a crash or could cause injury or death, you should immediately inform your Aston Martin Dealer or the manufacturers Service Operations Department at the address shown.

Aston Martin Lagonda Limited
 Service Operations Department
 Banbury Road
 Gaydon
 WARWICK
 CV35 0DB
 England

Telephone:

(International) +44 1926 644700
 (United Kingdom) 01926 644700
 Facsimile (+44) 1926 644733

Vehicle Provenance

Model:

e.g. Manual, Automatic

First Owner:

Selling Dealer

Third Owner:

Selling Dealer

Body Colour:

Interior Colour:

Delivery Date

Delivery Date

Fascia Colour:

Vehicle Identification Number (as shown on the Aston Martin manufacturer's label):

As on the VIN plate

Second Owner:

Selling Dealer

Fourth Owner:

Selling Dealer

Delivery Date

Delivery Date

Fifth Owner:

Selling Dealer

Delivery Date

Sixth Owner:

Selling Dealer

Delivery Date



ASTON MARTIN



ASTON MARTIN



ASTON MARTIN



ASTON MARTIN



ASTON MARTIN



Vehicle Security

Introduction	2.2
Vehicle Key	2.2
Unlocking and Opening	2.3
Locking	2.4
Master Locks	2.4
Fuel Flap Release	2.4
Tailgate	2.5
Deadlocking.....	2.5
Alarm	2.6
Passive Anti-Theft System	2.6
Personalisation	2.7

Introduction

This vehicle is protected by an electronic security system which sounds an alarm and flashes lights when forcible entry is detected.

The alarm is triggered in the following situations:

- A locked door is unlocked or opened in any way other than using the vehicle key
- The bonnet is opened whilst the vehicle is locked
- The rear window is tapped or broken
- The battery is reconnected

Vehicle protection is enhanced by a Passive Anti-Theft System (PATS) which provides engine immobilisation if the wrong vehicle key is used.

Vehicle Key

The vehicle is supplied with two vehicle keys and one key number plate.

 *The driver should always carry the vehicle key.*

Keep the spare key and the key number plate in a safe place. Do not leave a vehicle key in the vehicle when unattended.

If the vehicle key battery is depleted or the entry function does not operate properly, you will need the mechanical key. To take out the mechanical key push the release button and take the key out. After using the mechanical key, store it in the electronic key.

 *If a vehicle key is lost, contact your Aston Martin Dealer.*

'Reduce the impact of electromagnetic waves, please apply proper use'

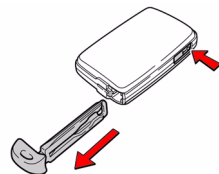

Keyless Entry and Start

The vehicle can be locked and unlocked simply by carrying the vehicle key on your person, for example in your pocket.

The two vehicle keys incorporate the keyless entry and start system. When locking or unlocking the doors, the system can be operated when the vehicle key is within about 0.7 m of an outside door handle (Refer to 'Unlocking and Opening', page 2.3).

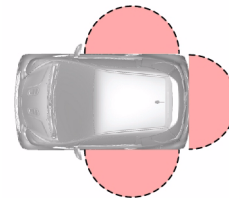

Unlocking and Opening

Vehicle Key Security Functions

[1] LOCK - Press and release for one step vehicle locking and to arm the security system.

[2] UNLOCK - Press and release for one step vehicle unlocking.

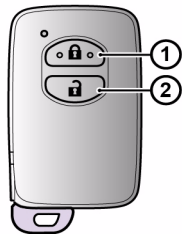

With the vehicle key on your person, stand within 0.7 m of the door and grip the handle to unlock the vehicle, making sure to touch the sensor on the back of the handle. To show that the security system has been disarmed, the direction indicators will flash twice. All vehicle doors will unlock.

 *The door cannot be unlocked for three seconds after the door is locked.*

If a door is opened whilst driving a warning sound will be heard until the door is closed.

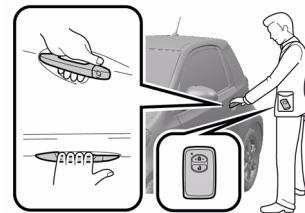

 *The doors may not be unlocked when a door handle is operated quickly, or if you suddenly enter the operating range of the exterior antenna and operate a door handle. In this case, return the door handle to its original position, unlock the doors again, and then check that the doors are unlocked before pulling the door handle.*

When taking hold of a door handle whilst wearing gloves, the unlocking response may become slow or the doors may not be unlocked.

If there is another vehicle key in the operating range, the response time to unlock the doors after a door handle is taken hold of may become longer.

 *As the vehicle is unlocked, the interior lamp will come ON. The lamp will go OFF 15 seconds after doors are closed or when the "ENGINE START STOP" switch is turned to ACCESSORY mode, whichever is sooner.*

Locking

Make sure that the doors and the tailgate are closed (the vehicle will not lock if a door is left open). With the vehicle key on your person, stand within 0.7 m of the door and touch the lock sensor (1) to lock the vehicle.

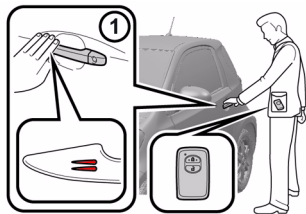

Alternatively, stand within 0.7 m of the tailgate and touch the lock button (2).

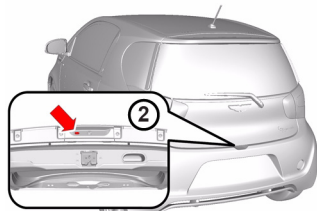

The direction indicators will flash once as the security system is armed.

Automatic Re-locking

If the vehicle is locked and then unlocked but a door or the tailgate is not opened within approximately 30 seconds, the vehicle will automatically lock and arm again.

Master Locks

The doors and the tailgate may be unlocked (1) or locked (2) by using the master lock switch.

If the vehicle is locked using the master lock switch, one pull of the driver's door handle will open the door. The passenger's door cannot be opened without unlocking the vehicle using the vehicle key or the master lock switch.

The master lock switch will not operate if the vehicle has been locked from the outside.

 *In the event of a vehicle accident the doors will automatically unlock.*

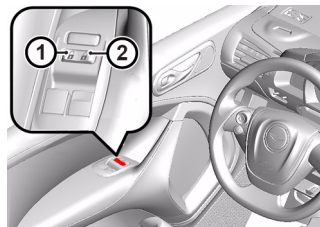

Fuel Flap Release

To open the fuel tank cap pull up the fuel filler door opener (located to the left of the driver's seat). Before refuelling the vehicle make sure that the doors and windows are closed and turn the "ENGINE START STOP" switch OFF.

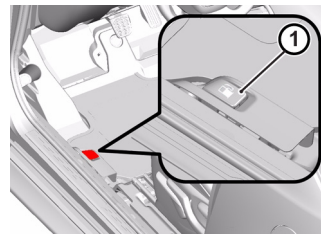

Tailgate

To Open the Tailgate

With the vehicle key on your person, stand within 0.7 m of the tailgate and then lift the tailgate whilst pressing and holding the unlock button.

 If the vehicle is locked and armed the security system will disarm and the direction indicators will flash twice when the tailgate is opened. The doors will stay locked.

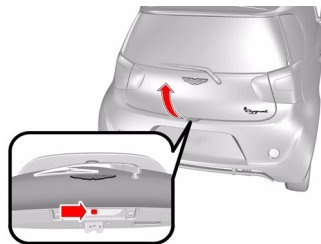

To Close the Tailgate

Lower the tailgate using the tailgate handle, and make sure to push the tailgate down from the outside to close it.

 Always make sure that the tailgate is securely closed after use.



Deadlocking

 **Never activate the deadlocking system when there are people in the vehicle. The doors cannot be opened from inside the vehicle.**

Unauthorised access to the vehicle is prevented by disabling the door unlocking function from both the interior and exterior of the vehicle. Vehicles employing this system have labels on the window glass of the doors.

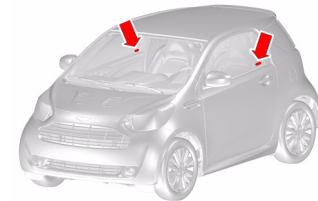



To set the deadlocking system turn the “ENGINE START STOP” switch OFF, have all of the passengers exit the vehicle and make sure that the doors are closed. Then, with the vehicle key on your person, touch the lock sensor on the outside handle or press the lock button on the tailgate, twice within five seconds. Alternatively, press the **LOCK** button on the vehicle key twice within five seconds.

To open the doors hold the outside door handle on the driver's side. Alternatively, press the **UNLOCK** button on the vehicle key.

Alarm

To set the alarm close the doors, the tailgate and the bonnet, and then lock the doors using the lock sensor on the door handle, the lock button on the tailgate, or the **LOCK** button on the vehicle key. The system will be set automatically after 30 seconds.

 The indicator light  on the instrument cluster changes from being ON to flashing when the system is set.

Stop the alarm at any time by pressing the **UNLOCK** button on the vehicle key.

Passive Anti-Theft System

The Passive Anti-Theft System (PATS) is a fully automatic engine immobiliser.

 If a vehicle key is lost, a duplicate key can be created and programmed from the spare key by your Aston Martin Dealer.

Starting the Engine

When the security system is disarmed, the vehicle key is within range and the "START STOP SWITCH" is turned to ACCESSORY or IGNITION ON mode, the PATS controller sends a signal to the vehicle key. The vehicle key must respond with a valid code before engine start will be enabled. If a valid code is received, the ignition system will operate normally. If the vehicle key code is not received, or is invalid, engine start stays disabled.

PATS Status

The PATS system state is shown by the  symbol on the instrument cluster (1).

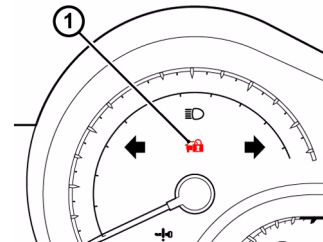

Ignition	Action (Valid code)
ON	Symbol comes ON for three seconds.
OFF	Symbol will flash continuously.

Fault Mode

If the status symbol continues flashing when the “START STOP SWITCH” is set to IGNITION ON, the vehicle will stay immobilised.

Should this situation arise try switching the “START STOP SWITCH” to OFF, and then back to IGNITION ON. If this is unsuccessful try the spare key. If successful, get a replacement for the faulty vehicle key. If problems continue with the vehicle key, consult your Aston Martin Dealer.

Personalisation

A number of security functions can be personalised. Programming these preferences requires specialised equipment and may be performed by an Aston Martin Dealer.

Some function settings are changed simultaneously when other functions are personalised.

Item	Function	Default Setting	Personalised Setting
Keyless Entry and Start System	Keyless Entry and Start System	ON	OFF
	Operation signal (Emergency flashers)	ON	OFF
Vehicle Key	Wireless remote control	ON	OFF
	Time elapsed before automatic door lock function is activated if door is not opened after being unlocked	30 seconds	60 seconds 120 seconds
	Operation signal (Emergency flashers)	ON	OFF
	Door lock buzzer	ON	OFF



ASTON MARTIN



ASTON MARTIN



ASTON MARTIN

Before Driving

Before Driving.....	3.2	Passenger Airbag Deactivation.....	3.15
Seat Adjustment.....	3.2	ISOFIX Anchors.....	3.16
Temperature Controlled Seats.....	3.5	Tether Anchors.....	3.16
Steering Wheel.....	3.6	Automatic Locking Retractors.....	3.17
Interior Mirrors.....	3.6	Child Seats.....	3.18
Door Mirrors.....	3.7	Cabin Storage.....	3.21
Restraints System.....	3.8	Accessory Socket.....	3.23
Seat Belts.....	3.8	Electric Windows.....	3.24
Airbags.....	3.12	Reading Lamps.....	3.25
Child Safety.....	3.13		

Before Driving

Checks Before Driving

Inspect your vehicle to make sure that everything is according to the information and specifications in this Owner's Guide.

Outside the Vehicle:

- Visually check the road wheels, wheel nuts and tyres
- Check that all windows, mirrors and lamps are clear and unobstructed
- Check that the tailgate, bonnet and fuel filler flap are securely closed
- Check the operation of all lamps

Once Inside the Vehicle:

- Check that the doors are securely closed
- Check that the seat, mirrors and steering wheel adjustments are correct
- Check that all gauges and symbols are reading correctly
- Check that all passengers have fastened their seat belts

Seat Adjustment

Front Seats

⚠ Warning: Do not attempt to adjust the driver's seat whilst driving.

⚠ Warning: Do not place a cushion between the driver or passenger and the seat back. A cushion may prevent the correct posture from being achieved, and reduce the effectiveness of the seat belt and head restraint, increasing the risk of death or serious injury to the driver or passenger.

⚠ Warning: Do not place anything under the front seats.

Objects placed under the front seats may become jammed in the seat tracks and stop the seat from locking in place. This may lead to an accident. The adjustment mechanism may also be damaged.

⚠ Warning: Take care when adjusting the seat position to make sure that other passengers are not injured by the moving seat.

⚠ Warning: Do not put your hands under the seat or near the moving parts to avoid injury.

Fingers or hands may become jammed in the seat mechanism.

The seat adjustment controls are located on each side of the front seats.

Driver's Seat

[1] - Move the seat **forwards** or **rearwards**.

[2] - Increase or decrease the **angle of the seat back**.

[3] - Move the seat **upwards** or **downwards**.

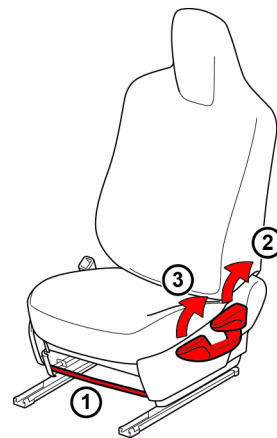

Passenger's Seat

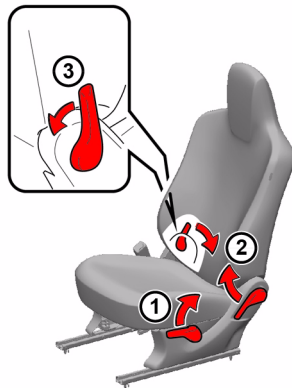

The front passenger's seat can be adjusted to give easy access to the rear seat.

Lift up the seat back angle adjustment lever (2). When the seat back is folded to the forward limit, the seat can slide back and forth.

Slide the seat to the most forward position. After the rear passengers get into the vehicle, slide the seat backwards until it locks. By raising the seat back, the seat locks in the upright position.

To exit the vehicle, the rear passengers can use the seat back angle adjustment lever (3).

Seat Head Restraints

The driver and front passenger seats include non-adjustable head restraints (1), which limit the rearward travel of the head in a rear impact and may reduce whiplash injuries.

When sitting in the seats make sure that the seat back is in an upright position and that the rear of the head is positioned in the centre of the head restraint area. The head restraints are most effective when the distance between the rear of the head and the head restraint is kept to a minimum.



Rear Seat

⚠ Warning: Do not adjust the rear seat whilst the vehicle is moving. Stop the vehicle on level ground, set the parking brake ON and make sure that the vehicle is in Park (Automatic) or first gear (Manual).

⚠ Warning: Do not place anything that may roll, or is larger than the available space under the seat.

⚠ Warning: Do not drive with the seat cushion raised.

⚠ Warning: Do not allow anyone to sit on a folded seat back or in the luggage compartment whilst driving.

⚠ Warning: After returning the rear seat to its original position make sure that the seat back and bottom cushion are securely locked and that the seat belts are not twisted or caught under the seat.

To Lower the Rear Seat Back

The rear seat back can fold down to give more boot area storage options.

Stow the seat belt buckles.

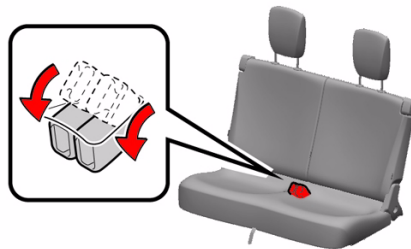

Pull the lock release lever and fold the seat back until it reaches the position where the head restraints can be removed.

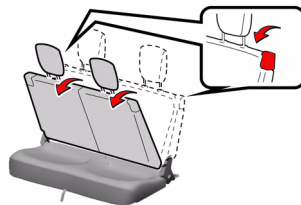

Remove the head restraints by pulling them upwards whilst pushing the lock release button.

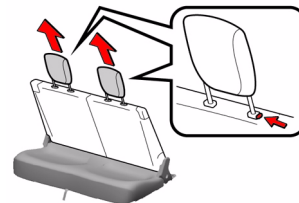

Fold down the seat back and stow the head restraints in the pockets in the front seat backs.

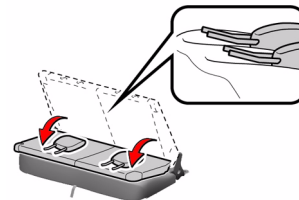

Temperature Controlled Seats

To Store the Rear Seat Cushion

The rear seat cushion can also be stowed to give more storage options.

Pull the strap horizontally. The latch under the seat cushion will release, allowing the seat cushion to be lifted.

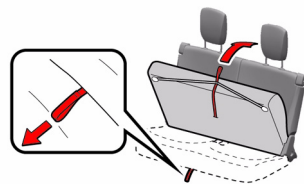

Release the button and open the strap.

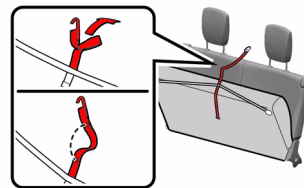

Anchor the strap to the head restraint.

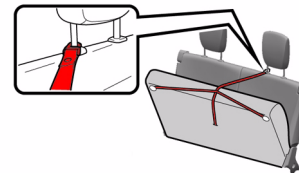

The front seats can be heated. Use the individual seat controls to switch on the heaters. The indicator lights will illuminate when the seat heaters are ON.

 *The seat heaters can be used when the "ENGINE START STOP" switch is in IGNITION ON mode.*

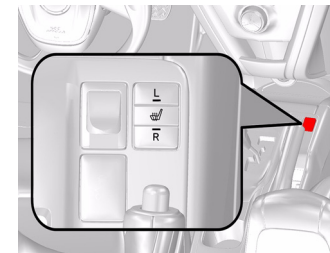

Steering Wheel

Steering Lock

When the “ENGINE START STOP” switch is turned OFF and then a door is opened and closed, the steering lock function locks the steering wheel in its current position. The steering lock is disabled when the “ENGINE START STOP” switch is operated again.

To release the steering wheel lock, gently turn the steering wheel left or right whilst pressing the “ENGINE START STOP” switch. If the steering wheel lock does not release, the “ENGINE START STOP” switch indicator will flash green.

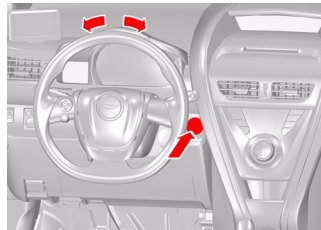

Tilt

⚠ Warning: Do not adjust the steering wheel whilst driving.

⚠ Warning: Make sure that the steering column is fully locked in position. The tilt release lever must be fully up, in line with the steering column.

The tilt angle of the steering wheel is adjusted by using the release lever (1). Pull the release lever downwards and manoeuvre the steering wheel to the required position. Hold the steering wheel in the required position and lock it by pulling the release lever up.

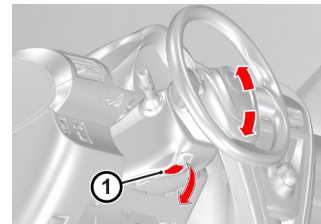

Interior Mirrors

Automatic Anti-Glare Rear View Mirror

Adjust the rear view mirror on its ball mounting until a satisfactory rear view is obtained.

The rear view mirror will dim automatically if the glare from the headlamps of following vehicles becomes too bright. The mirror will return to normal view as unwanted glare reduces to an acceptable level.

To turn the automatic mode ON or OFF, use the button on the rear view mirror. The indicator comes on when automatic mode is turned ON.

 The mirror will revert to the automatic mode each time the “ENGINE START STOP” switch is turned to IGNITION ON mode.

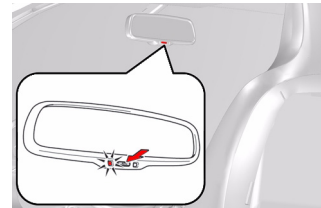

To make sure that the sensors operate properly, do not touch or cover them.

Vanity Mirror

A vanity mirror is located in each sun visor.

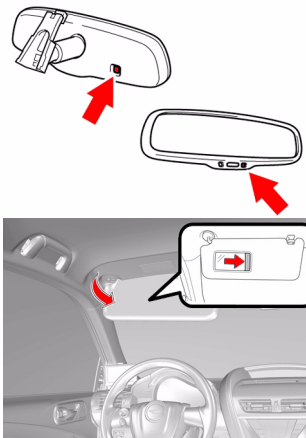

Door Mirrors

To adjust the door mirrors select the left or right mirror (1). Then move the switch (2) up, down, left or right to adjust the selected mirror.

 The "ENGINE START STOP" switch must be turned to ACCESSORY or IGNITION ON mode before the door mirrors can be adjusted.

Heated Mirrors

When the heated rear window is ON the heaters in the door mirrors will operate for 15 minutes (Refer to 'Climate Controls', page 6.2).

 **Warning: Do not touch the door mirror surfaces when the heaters are in operation. They can become very hot and may burn you.**

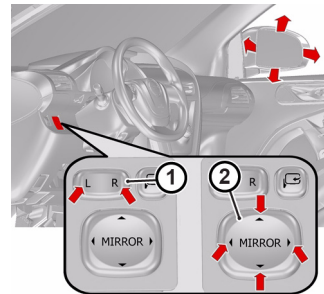

Power Fold Function

The power fold mirror function moves the door mirror assemblies until folded flat against the doors (folded).

Move the mirrors to the folded position by pressing the power fold button. The mirrors will motor to the folded position. Repeat to motor the mirrors back to the driving position.

 The power fold mirror function can be used when the "ENGINE START STOP" switch is in ACCESSORY or IGNITION ON mode.

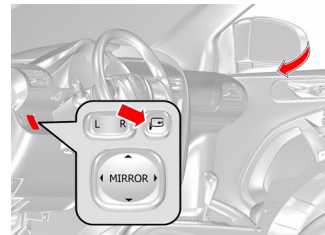

Restraints System

The restraints system gives protection to the driver and all passengers in a variety of impact conditions. The system consists of:

- Driver and passenger safety belts with pre-tensioners and load limiting systems
- Driver front airbag
- Driver knee bolster airbag
- Driver and front passenger seat side airbags
- Front passenger twin chamber airbag
- Front passenger seat cushion airbag
- Front Passenger Airbag Deactivation (PAD) switch
- Front Passenger Sensing
- Side curtain airbags
- Rear window curtain shield airbag

All of these systems are controlled by a Restraints Control Module (RCM). In a collision the RCM will analyse information from various sensors, including crash and seat occupancy conditions. Based on this information the RCM will deploy the appropriate safety devices.

During a crash, the RCM may or may not operate the safety belt pre-tensioners and none, some or all of the airbag supplemental restraints.

If the pre-tensioners or airbags do not operate in a collision it does not mean that something is wrong with the system. Rather, it means the system determined the accident conditions (crash severity, belt usage, etc.) were not appropriate to operate these safety devices.

Front airbags are designed to operate only in frontal and near-frontal collisions, not rollovers, side-impacts, or rear-impacts unless the collision causes sufficient longitudinal deceleration.

Determining if the System is Operational

A warning symbol in the instrument cluster  shows the condition of the system.

When the "START STOP SWITCH" is set to IGNITION ON, this symbol comes ON for a few seconds as a readiness sign. If it does not come ON, or if it does not go OFF after a few seconds, or if it comes ON whilst driving, the airbag self diagnostic system has detected a fault.

If either of these conditions occur, even intermittently, have the restraint system serviced at your Aston Martin Dealer immediately. Unless serviced, the system may not operate correctly in the event of a collision.

Seat Belts

Aston Martin strongly recommend the use of seat belts.

⚠ Warning: Seat belts should not be worn with straps twisted.

⚠ Warning: Each belt assembly must only be used by one passenger; it is dangerous to put a belt around a child being carried on the passenger's lap. Do not put an adult seat belt around two children.

⚠ Warning: When installed, the seat belt webbing must not contact any sharp edges which could abrade or cut the webbing during normal use or in an accident. If necessary, the webbing must be protected.

⚠ Warning: Wearing your seat belt is crucial to your safety. Not wearing a seat belt increases chance of serious injury or death in the event of an accident.

⚠ Warning: Be sure that you and your passengers always fasten their seat belts and use them correctly even though airbags are provided.

⚠ Warning: Reclining the seat back decreases protection provided by the seat belt in the event of a crash. Adjust the seat back to an upright position.

⚠ Warning: *Seat belts are designed to bear upon the bony structure of the body, and should be worn low across the front of the pelvis, chest and shoulders; wearing the lap section of the belt across the abdominal area must be avoided.*

⚠ Warning: *Never place shoulder portion of belt under your arm or behind your back.*

⚠ Warning: *Always remove from your pockets rigid or breakable objects, i.e. spectacles or a mobile phone, which could be trapped under seat belts, possibly causing injury in the event of an accident.*

⚠ Warning: *Expectant mothers should seek medical advice on the most appropriate way to wear the seat belt.*

⚠ Warning: *Seat belts must be kept clean so that the retractor works correctly. Make sure that belt webbing is not twisted, looped, frayed or obstructed in any way. If in doubt about condition or operation of seat belt installation, have it checked by your Aston Martin Dealer.*

⚠ Warning: *No modifications or additions should be made by the user which will either prevent seat belt adjusting devices from operating, or prevent seat belt assembly from being adjusted to remove slack. Never install accessories on your seat belts.*

⚠ Warning: *Seat belts should be adjusted as firmly as possible, consistent with comfort, to provide the protection for which they have been designed. A slack belt will greatly reduce the protection afforded to the wearer.*

⚠ Warning: *It is essential to replace the entire seat belt assembly after it has been worn in a severe impact even if damage to the seat belt assembly is not obvious.*

Pre-tensioner and Load Limiting

All seat belts are equipped with pre-tensioner and load limiting systems.

In most moderate frontal or near frontal accidents, the front airbag and all pre-tensioner systems will deploy simultaneously.

The pre-tensioners take up slack in the seat belts as the airbags are expanding. The load limiting system releases belt webbing in a controlled manner to reduce belt force on the passenger's chest.

 *In some moderate frontal or near frontal accidents, only the pre-tensioner system will deploy.*

Seat Belt Reminder

Driver

A warning symbol in the instrument cluster will come ON  and the driver's seat belt reminder sounds to alert the driver that his or her seat belt is not fastened. The buzzer sounds for 30 seconds after the vehicle has reached a speed of at least 20 km/h. Then, if the seat belt is still unfastened, the buzzer will sound in a different tone for a further 90 seconds.

Front Passenger

A warning symbol in the centre panel display will come ON  and the driver's and front passenger's seat belt reminder sounds to alert the driver and front passenger that his or her seat belt is not fastened. The buzzer sounds for 30 seconds after the vehicle has reached a speed of at least 20 km/h. Then, if the seat belt is still unfastened, the buzzer will sound in a different tone for a further 90 seconds.

PASSENGER

Rear Passengers

A warning symbol in the centre panel display will come ON  and the rear passenger's seat belt reminder sounds to alert the rear passenger that his or her seat belt is not fastened. The buzzer sounds for 30 seconds after the vehicle has reached a speed of at least 20 km/h. Then, if the seat belt is still unfastened, the buzzer will sound in a different tone for a further 90 seconds.

Seat Belt Fastening

 *When parked on an incline, the seat belt may lock as it is withdrawn. This is not a fault. If the mechanism locks, release the belt tension and then pull the belt very gently to avoid operation of the inertia lock.*

Each seat has three point, inertia reel seat belts installed. Items 1, 2 and 3 show the three points of the seat belt. Item 3 is also the location of the belt buckle.

The inertia belt reels will automatically tension the belts to provide security with comfort. In the event of a collision or during severe braking, the belt reels will lock.

Pull out the seat belt, drawing the tongue over the shoulder and across the chest.



Push the tongue into the belt buckle latch until a positive click is heard.

Pull upwards on the diagonal belt to make sure that the latching is secure and to remove all slack from the belt.

Finally, double check that the lap belt is installed snugly, low down across the hips, and that there are no twists.

If it is necessary for a passenger to adjust their seat or seating position during a journey, the belt tension might be disturbed.



The passenger should therefore (as soon as it is safe to do so) gently pull down the shoulder run of the seat belt to create some slack and then immediately release it to re-tension the belt for the new seating position.



Seat Belt Unfastening

Depress the button on the buckle. whilst holding the seat belt tongue allow the belt to slowly retract to its stored position.

Child Seat Belt Fastening

⚠ Warning: An infant or child that is not correctly restrained can be seriously injured or killed in a crash. Seat belts are designed for adults and larger children; infants and smaller children must be restrained in an approved child safety seat.

Make sure that there is no slack in the webbing and that the restraint installs correctly across the child's rib cage and hips. These are the parts of the body most able to take the force of impact.

The lap strap should pass across the top of the child's thighs, bearing on the pelvis, not on the abdominal area.



Airbags

Supplemental Restraints System

The vehicle is equipped with driver and passenger airbags. The airbags and seat belt pre-tensioners are electrically controlled by the restraints system.

The front airbags (1, 2 and 3) only deploy in a serious front collision. The side airbags, located in the front seats (4) and the door top panels (5) only deploy according to which side has been impacted in a serious side collision. The airbags mounted in the door top panels on each door are designed to protect the heads of the driver and passengers during certain side impacts.

The rear airbag (6) will deploy when the passenger compartment is subjected to a serious collision from the rear.

The purpose of the airbags is to provide **additional** protection for the driver and passengers in the event of a serious impact (front or side impacts). The airbags are supplementary to the seat belts.

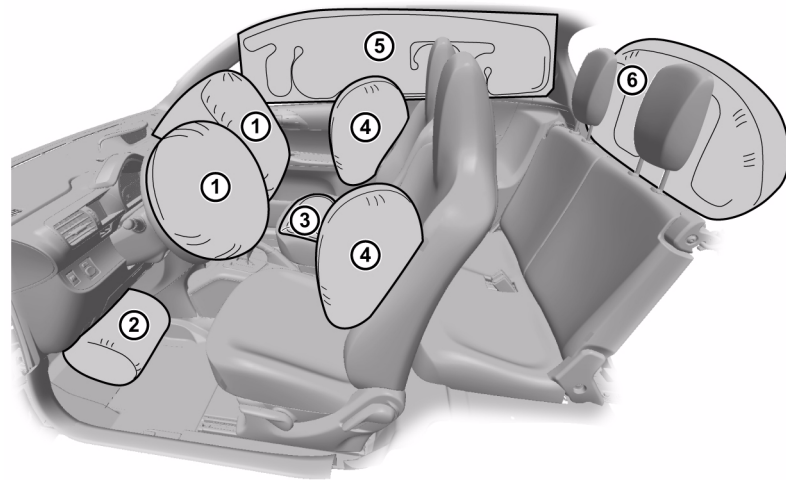

Important airbag safety labels are located on the sun visors and on the end of the instrument panel (passenger side). Make sure that the instructions on these labels are read and complied with before driving the vehicle.

Airbag Deployment

⚠ Warning: The use of accessory seat covers may prevent the deployment of the side airbags and increase the risk of injury in an accident. Do not use accessory seat covers.

⚠ Warning: All passengers, including the driver, should always wear seat belts, whether or not an airbag is provided, to decrease the risk of injury or death in the event of a crash.

⚠ Warning: No objects whatsoever should be attached to the centre cover of the steering wheel or the front passenger fascia panel. Such objects could cause harm if the vehicle is in a collision severe enough to cause the airbags to deploy.

Airbags inflate rapidly and with considerable force; there is therefore a risk of death or serious injury such as fractures, facial and eye injuries or internal injuries, particularly to passengers who are not correctly restrained by seat belts or are not sitting correctly when the airbags deploy. The risk of injury from a deploying airbag is greatest close to the trim panel covering the airbag.

The whole sequence of events from sensing the impact to full inflation of the airbag takes place in a fraction of a second. The noise and gas associated with the deployment of the airbags is not injurious to health.

Do not change, modify or tamper with the steering wheel, passenger side fascia or any other part of the airbag system. Such actions could disable the system or cause inadvertent airbag deployment.

The system will not deploy in the event of minor frontal or side impacts, such as contacts when parking.

All work on the airbag system must only be carried out by an Aston Martin Dealer.

Child Safety

Aston Martin strongly recommends:

- **That all children are seated in the rear passenger seats.**
- **Not to install any child seat on the front passenger seat of this vehicle.**
- **Always use ISOFIX anchors where available.**

A child, regardless of age, should always be restrained when travelling in a vehicle.

⚠ Warning: Accident statistics show that children are generally safer when correctly restrained in the rear seat than in the front seat. A suitable child restraint, correctly installed and used, provides the highest degree of protection for infants and small children in most accident situations.

⚠ Warning: Do not allow children to travel in a vehicle without restraint. An appropriate child seat or harness should always be used.

⚠ Warning: Each seat belt assembly must be used by only one passenger. It is dangerous to put a seat belt around a child being carried on the passenger's lap.

⚠ Warning: Make sure that an installed child seat does not rest against the door, that the child sits correctly in the seat and does not lean close to, or against, the door or window.

Your vehicle has the following devices for the installation of child restraints:

- Passenger Airbag Deactivation (PAD) switch
- ISOFIX anchors¹ (rear passenger seats only)
- Front Passenger Sensing system
- Passenger seats Automatic Locking Retractor (ALR) seat belts
- Tether anchor points (rear passenger seats only)

Child Seats and Front Passenger Airbag

⚠ Warning: Extreme Hazard! Do not use a rearward facing child seat on a seat protected by an airbag in front of it.

⚠ Warning: Do not use a child restraint on a seat protected by a front airbag which is set to ON.

⚠ Warning: With the exception of installing a child seat on the front passenger seat, do not set the PAD switch to OFF, as the front passenger will not receive the added protection of the airbag. Serious injuries or even death could occur.

⚠ Warning: Never place a child in a child seat or on a booster cushion on the front passenger seat if the airbag is set to ON.

If a child seat is to be used in the front passenger seat, the front passenger airbag **must** be set to OFF. Make sure that the child seat manufacturer's installation instructions are followed correctly.

 The PAD switch does not set the front passenger side impact airbags or the seat belt pre-tensioners to OFF.

Warning Labels

⚠ Warning: Extreme Hazard: Do not use a rearward facing child restraint on a seat protected by an active airbag in front of it.

The following warning label² is located on the end of the instrument panel (passenger side).

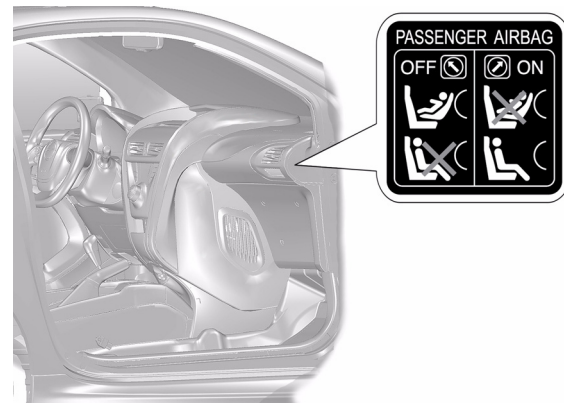

¹ Standard for installing child seats into cars and is intended to make the installation of child seats quick and simple

² Market area dependant.

Passenger Airbag Deactivation

⚠ Warning: Before installing a child seat on the front passenger seat, the front passenger airbag must be set to OFF.

⚠ Warning: Before driving always confirm that the PAD switch is in the appropriate position according to your requirements.

⚠ Warning: With the exception of installing a child seat on the front passenger seat, do not set the PAD switch to OFF, as the front passenger will not receive the added protection of the airbag. Serious injuries or even death could occur.

 The PAD switch does not set the passenger seat side impact airbags or the seat belt pre-tensioners to OFF.

The Passenger Airbag Deactivation (PAD) switch lets the airbag protecting the front passenger be set to OFF. When the PAD is set to OFF a child seat may be installed on the front passenger seat.

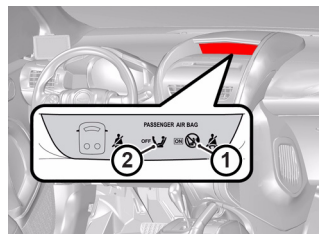

At IGNITION ON if the front passenger airbag is set to ON the “PASSENGER AIRBAG ON” symbol (1) will show in the centre panel display. If the front passenger airbag is set to OFF the “PASSENGER AIRBAG OFF” symbol (2) will be shown instead.

The PAD switch is located on the instrument panel underneath the steering column.



The PAD switch should be inspected by an Aston Martin Dealer if any of the following conditions occur:

- Neither the “PASSENGER AIRBAG OFF” symbol or the ‘PASSENGER AIRBAG ON’ symbol come on
- The “PASSENGER AIRBAG OFF” symbol stays ON when the ignition is set to ON and the passenger airbag is set to ON
- The “PASSENGER AIRBAG ON” symbol stays ON when the ignition is set to ON and the passenger airbag is set to OFF

Set the Airbag to ON or OFF

Insert the mechanical key into the PAD switch and turn counterclockwise for the OFF position (airbag OFF) or clockwise for the ON position (airbag ON). Remove the key.



Airbag ON - When the ignition is ON make sure that the "PASSENGER AIRBAG ON" symbol comes ON. Failure to follow the advice given above can endanger the life of the child.

Airbag OFF - Make sure that the "PASSENGER AIRBAG OFF" symbol stays ON when the ignition is ON.

ISOFIX Anchors

⚠ Warning: An unsecured child seat is dangerous. In a sudden stop or a collision it could move, causing serious injury or death to the child or other passengers. Make sure the child seat is correctly secured in place according to the manufacturer's instructions.

⚠ Warning: When installing the child seat, make sure that there are no seat belts or foreign objects near or around the ISOFIX anchors. If seat belts or a foreign object prevents the child seat from being securely attached to the ISOFIX anchors, the child seat could move in a sudden stop or collision causing serious injury or death to the child or other passengers.

This vehicle is equipped with ISOFIX (International Standards Organisation FIX) anchors for the installation of child seats on the rear passenger seat. The position of the anchors is shown by two tags at the base of the seat.

Secure the child seat using the ISOFIX anchors, following the child seat manufacturer's instructions.

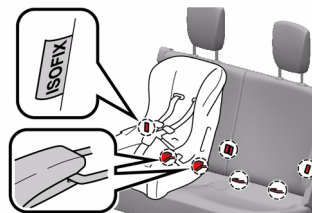

Tether Anchors

⚠ Warning: An infant or child that is not properly restrained can be seriously injured or killed in a crash. Seat belts are designed for adults and larger children; infants and smaller children must be restrained in an approved child safety seat.

⚠ Warning: Make sure that the child seat tether strap is always used when installing a child seat with ISOFIX anchors.

⚠ Warning: Child restraint anchorages are designed to withstand only those loads imposed by correctly fitted child restraints. Under no circumstances are they to be used for adult seatbelts, harnesses or for attaching other items or equipment to the vehicle.

⚠ Warning: Always follow the child seat manufacturer's instructions. Not following the child-seat manufacturer's instructions when installing the child seat is dangerous.

⚠ Warning: Make sure the child seat tether strap is free from obstructions above and below. Do not place any items on the tether strap between the child seat and the tether anchor point. Do not place tether strap over any items between the child seat and the tether anchor point.

A tether is a strap that connects the top of a child seat to a tether anchor point on the vehicle to reduce excessive movement of the child seat in the event of a collision. The purpose of a tether strap is to provide additional protection for the child seat occupant in the event of a serious impact. The tether strap is supplementary to the seat belts.

The tether anchor points are located at the rear of the boot area.

Engage the tether clip to the anchor point as shown and make sure that the locking spring has fully closed to prevent accidental disengagement.

Always make sure that the tether strap length is adjusted to remove any slack.

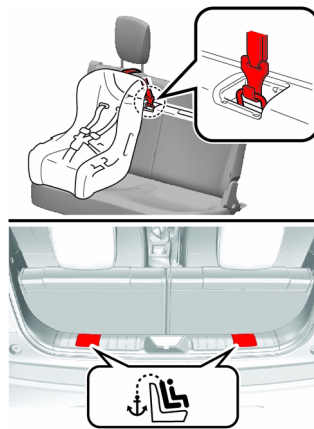

Automatic Locking Retractors

⚠ Warning: Always follow the child seat manufacturer's instructions. Not following the child-seat manufacturer's instructions when installing the child seat is dangerous.

Aston Martin does not recommend any specific child seat for this vehicle **which requires the use of the vehicle seat belt for installation.**

The Automatic Locking Retractor (ALR) system is designed to securely hold child seats. The ALR system temporarily locks the seat belt that is securing a child seat.

ALR Operation

Gently pull out the seat belt until fully extended. The ALR system will only engage at the maximum extension point of the seat belt.

Thread the belt tongue through the child seat as instructed by the child seat manufacturer. Engage the tongue into the belt buckle.

Adjust the tongue position on the belt, if necessary, to make sure that the lower belt run is tight and then allow the upper run of the seat belt to fully retract until the child seat is securely held. The ALR system will be heard 'clicking' as the seat belt retracts.

When fully retracted, pull down on the upper run of the belt to check that the ALR lock has engaged.

 When parked on an incline, the seat belt may lock as it is withdrawn. This is not a fault. If the mechanism locks, release the seat belt tension and then pull the seat belt very gently to avoid operation of the inertia lock.

The ALR system will disengage when the seat belt is fully retracted. The seat belt may then be worn when required as a normal seat belt. Once the ALR is disengaged, the seat belt must be fully extended to re-engage the system on the next occasion that a child seat is installed.

Child Seats

⚠ Warning: Always follow the child seat manufacturer's instructions. Not following the child seat manufacturer's instructions when installing the child seat is dangerous.

⚠ Warning: Do not seat a child aged 12 or younger, or weighing 36 kg or less in the car without an appropriate child seat or booster cushion.

Aston Martin recommends the installation of child seats which use ISOFIX and meet the Safety Standard ECE44. Contact your Aston Martin Dealer for more information.

Use of Child Seats

When installing child seats on the rear seat, adjust the front seat position so that the seat rails (3) are completely covered by the covers (1) bearing a triangle mark (2).

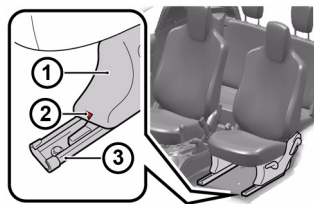

When installing child seats on the front seat, adjust the front seat position so that the seat back is in the most upright position (1), and the seat is as far back as possible (2).

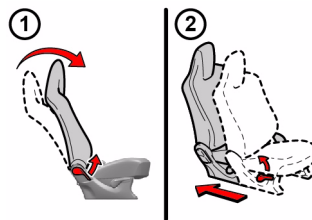

Look for the following when selecting a child seat:

- It should have a label certifying that it meets the applicable Safety Standards
- Carefully read the instructions supplied with the child seat. Make sure you understand them and can install and use the device correctly and safely in the vehicle
- Make sure that the child seat is appropriate for the child's weight and development. The label required by the standard or regulations, or instructions for infant seats, usually provide this information

An infant or child that is not correctly restrained can be seriously injured or killed in a crash. Seat belts are designed for adults and larger children; infants and smaller children must be restrained in an approved child seat.

Children could be endangered in a crash if their child seat is not correctly secured in the vehicle.

Never hold a baby or child on your lap whilst riding in the vehicle.

Consult with local manufacturers of forward facing restraint and booster cushions. These manufacturers can supply you with advice on the safety of their particular child restraints.

Check the seat manufacturers instructions for correct use and installation – use the correct size seat and correctly secure the seat in the vehicle in accordance with the manufacturers instructions. Be sure to read and follow the ‘Installation and Use Instructions’ provided with the child seat.

Child Seats - ISOFIX Installation

Always follow the child seat manufacturer’s instructions. Not following the child seat manufacturer’s instructions when installing the child seat is dangerous.

Mass Group ¹	Size Class	Fixture	ISOFIX Positions
	Carry Cot	F	Rear Outboard X
		G	X
‘0’	Up to 10kg (0-9 months)	E	X
‘0+’	Up to 13kg (0-18 months)	E	IL ₂
		D	X
		C	X
‘1’	9 to 18kg (9 months to 4 years)	D	X
		C	X
		B	IUF
		B1	₃ IUF
		A	X

¹. As shown on the child safety seat packaging

². Aston Martin branded Britax Baby - Safe Plus II

³. Aston Martin branded Britax Baby - Safefix Plus

Mass Group ¹	Size Class	Fixture	ISOFIX Positions
-------------------------	------------	---------	------------------

'II'	15 to 25kg (4 to 12 years)		X
'III'	(22 to 36 kg (4 to 12 years))		X

Key

IUF - Suitable for 'ISOFIX' forward child restraints systems of universal category approved for use in the mass group.

IL - Suitable for particular ISOFIX Child Restraint Systems (CRS). These ISOFIX CRS are those of the 'specific vehicle', 'restricted', or 'semi-universal' categories.

X - ISOFIX position not suitable for ISOFIX child restraint systems in this mass group or this size class.

Supplied under EC Directive 77/541.

¹. As shown on the child safety seat packaging

Child Seats - Seat Belt Installation

Consult with local manufacturers of forward facing restraint and booster cushions. These manufacturers can supply you with advice on the safety of their particular child restraints and also advice on installation instructions.

Mass Group ¹	Seating Position
-------------------------	------------------

'0'	Up to 10kg (0-9 months)	Front Passenger	Rear Outboard
'0+'	Up to 13kg (0-18 months)	U ₂	U
'I'	9 to 18kg (9 months to 4 years)	U	U
'II'	15 to 25kg (4 to 12 years)	U	L
'III'	(22 to 36 kg (4 to 12 years))	U	U

Key

L - Suitable for particular child restraint systems. These restraints may be of the 'specific vehicle', 'restricted' or 'semi-universal' categories.

U - Suitable for 'universal' category restraints approved for this mass group.

X - Seat position not suitable for children in the mass group.

* - Unsuitable for use with many child restraints due to limited space.

Supplied under EC Directive 77/541.

¹. As shown on the child safety seat packaging

². Move the passenger seat to its rearmost and highest position.

Cabin Storage

Glove Bag

Release the strap from the buckle to open.

Cup Holder

⚠ Warning: Only use the cup holder when safe to do so.

⚠ Warning: Do not place hot drinks in the cup holder whilst the vehicle is in motion. There is a risk of scalding.

⚠ Warning: Use soft cups only. Hard cups or objects can cause personal injury in a collision.

A cup holder is located in the floor console.

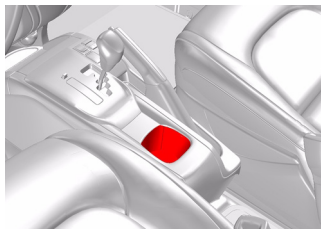

Bottle Holders

Bottle holders are located in the rear side trims.

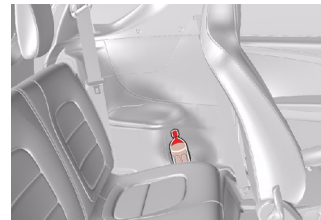

Door Pockets

The front doors have pockets.

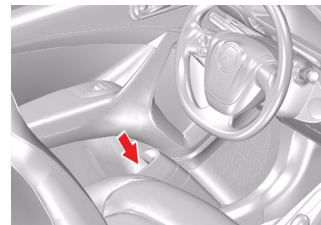

Rear Cubby Box

 *The Owner's Guide is stored in this location.*

The rear cubby box is located under the rear seat.

Pull the strap horizontally. The latch under the seat cushion will release, allowing the seat cushion to be lifted.

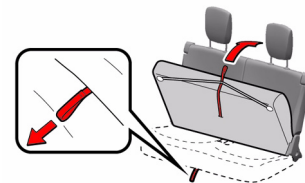

Release the button and open the strap.

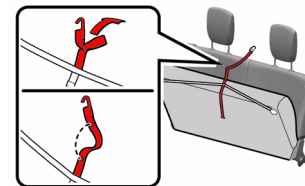

Anchor the strap to the head restraint.

 When returning the rear seat to its original position, put the strap back in its original place.

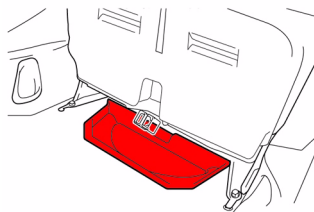
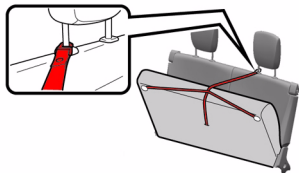

Rear Luggage Box

The rear luggage box is located behind the rear seat.

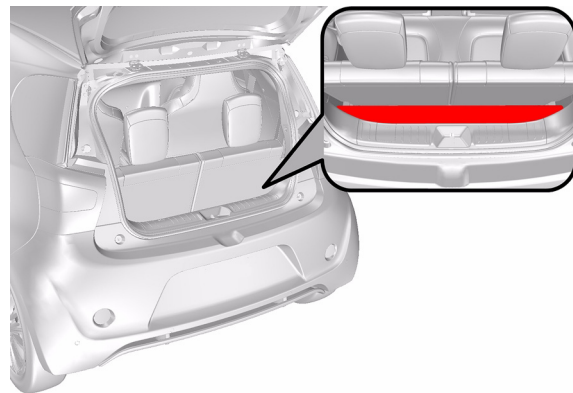

To access the rear luggage box, open the lid.

Warning Triangle and First Aid Kit Holder

The warning triangle and first aid kit holder is located underneath the rear luggage box.

To access these, stow the seat belt buckles.

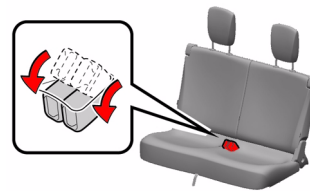

Pull the lock release lever and fold the seat back until it reaches the position where the head restraints can be removed.

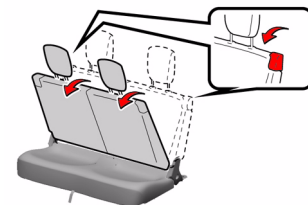

Remove the head restraints by pulling them upwards whilst pushing the lock release button.

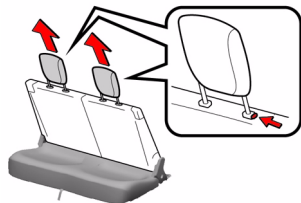

Fold down the seat back and stow the head restraints in the pockets in the front seat backs.

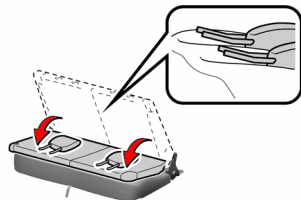

Turn and remove the knobs and then remove the rear luggage box.

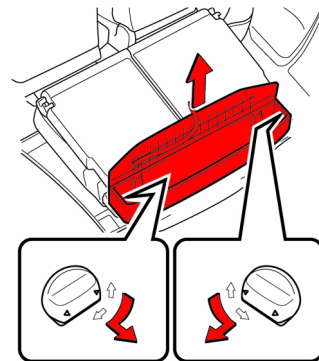

Accessory Socket

⚠ Warning: Damage to electrical circuits will result if more than 10 amps is drawn from the accessory socket. Only connect accessories which are designed for use in a motor vehicle.

⚠ Warning: Prolonged use of accessory socket when vehicle is stationary may seriously discharge battery.

⚠ Foreign objects can get into the socket and cause damage - always place the cover on the accessory socket when not in use.

The accessory socket is mounted in the centre stack and may be used to power any 12 volt vehicle accessory requiring a current of less than 10 amps.

Electric Windows

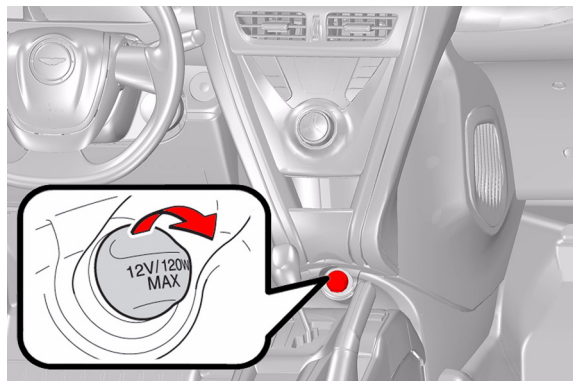

Read the manufacturer's instructions and make sure that you do not connect any device which would exceed current rating of the accessory socket.

 *The accessory socket can be used when the "ENGINE START STOP" switch is in ACCESSORY or IGNITION ON mode.*

 **Warning:** *Misuse of the window switches, especially by children, can result in injury due to entrapment in the window closure. Drivers must advise all passengers of the possible danger and make sure that all obstructions are clear before raising the window.*

 *The driver's window can be operated for approximately 45 seconds after the "ENGINE START STOP" switch is turned to ACCESSORY mode or turned OFF. However, they cannot be operated once either front door is opened.*

Each vehicle door has its own window switch and the driver's door window switch can operate both windows.

To raise and lower the windows the "ENGINE START STOP" switch must be in IGNITION ON mode.

Lightly press and hold a window switch to lower the window in one movement. Lightly press and release the window switch to lower the window in stages. Firmly press and release to lower the window with one touch.

Lightly pull back and hold to raise the window in one movement. Lightly pull back and release the window switch to raise the window in stages. Firmly pull back and release to raise the window in one movement.

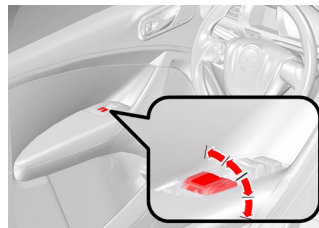

Window Anti-Trap

The anti-trap sensor detects an obstruction between the window glass and the window frame during window closing. The window will continue to close until the obstruction is detected, closing then stops and the window backs off. This is a safety feature designed to prevent inadvertent closing of a window on vulnerable parts of the body or other obstructions. Remove any obstruction and then close the window.

If, for any reason it is required to override the anti-trap mechanism, lift and hold the relevant window switch until the window has closed.

Door Window Lock

The passenger's window can be locked from the driver's side so that the passenger can not operate it. Open or close the window as required then press and release the door window lock button (1) to lock. Press and release again to unlock.



Reading Lamps

A reading lamp is located in the front environment (1).

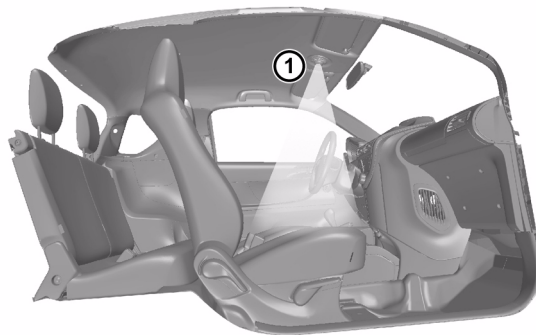

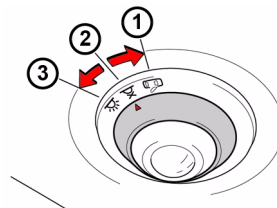

When the reading lamp switch is in the  position (1), the reading lamp automatically turns ON or OFF according to the presence of the vehicle key, whether the doors are locked/unlocked, whether the doors are open/closed, and the "ENGINE START STOP" switch mode.

The reading lamp can be switched OFF and ON manually by rotating the reading lamp switch to positions (2) and (3) respectively.

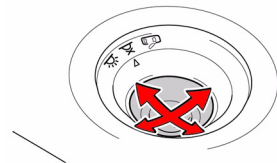

The reading lamp can also be adjusted to direct the light to a desired area of the cabin.



If the reading lamp remains ON when a door is not fully closed and the reading lamp switch is in the  position, the lamp will go OFF automatically after 20 minutes.

The time elapsed before the lamp turns OFF, along with other settings, can be changed. Programming these preferences requires specialised equipment and may be performed by an Aston Martin Dealer.



ASTON MARTIN



ASTON MARTIN

Controls

Controls Overview	4.2
Instrument Cluster	4.3
Information and Warning Symbols.....	4.3
Trip Computer	4.6
Centre Stack.....	4.9
Centre Console	4.9
Ignition Control	4.10
Stalk Controls	4.11
Vehicle Horn.....	4.13

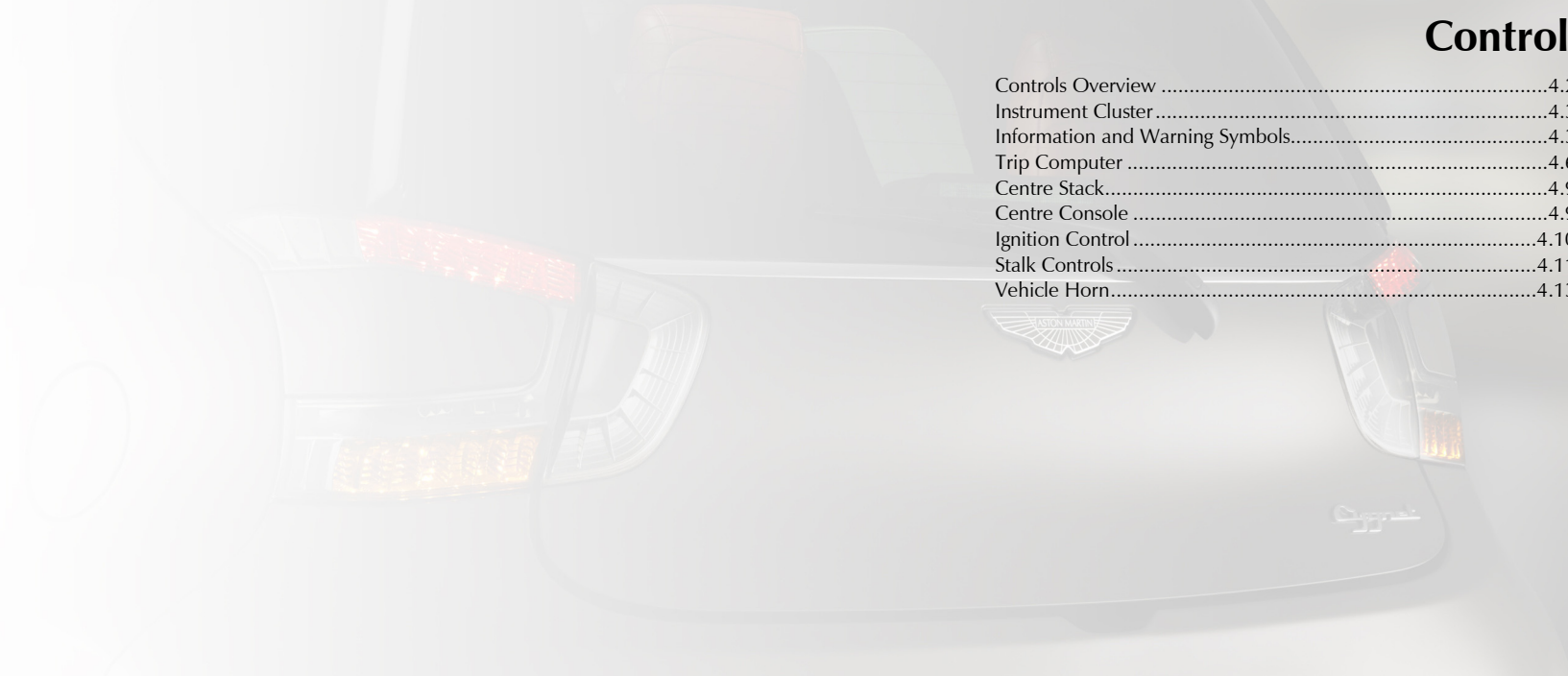

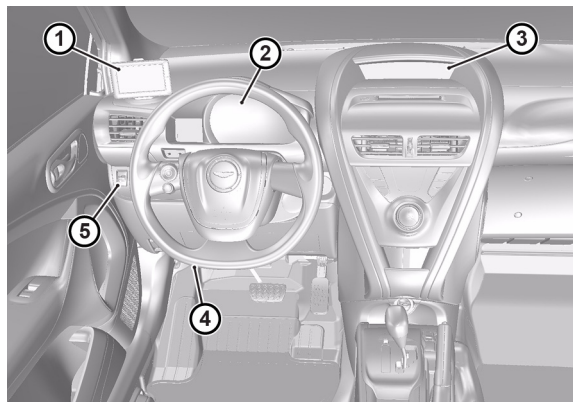

[1] SATELLITE NAVIGATION SCREEN - (Refer to 'Satellite Navigation', page 9.1)

[2] INSTRUMENT CLUSTER - (Refer to 'Instrument Cluster', page 4.3)

[3] CENTRE PANEL DISPLAY - Shows the status of airbags and seat belt use.

[4] AIRBAG DEACTIVATION - The passenger airbag **must** be set to OFF if installing a child seat on the front passenger seat (Refer to 'Passenger Airbag Deactivation', page 3.15).

[5] MANUAL HEADLAMP LEVELLING DIAL - The level of the headlamps can be adjusted according to the number of passengers and the loading condition of the vehicle.

[A] - Raises the level of the headlamps.

[B] - Lowers the level of the headlamps.

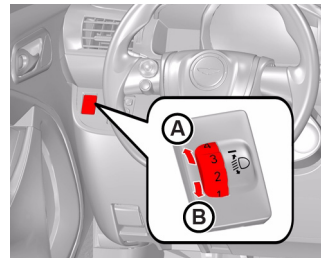

Guide to Dial Settings

Loading Condition	Dial Position
Driver only	0
Driver + one passenger in the front seat	1
Driver + one passenger in the front seats, and two passengers in the rear seat	3
Driver + one passenger in the front seats, two passengers in the rear seat, and full luggage	4.5

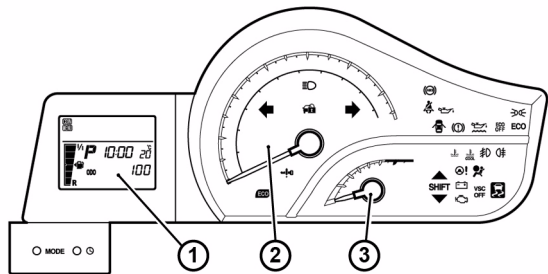

- [1] **TRIP COMPUTER** - (Refer to 'Trip Computer', page 4.6)
- [2] **SPEEDOMETER** - Shows vehicle road speed.
- [3] **TACHOMETER** - Shows the engine speed in revolutions per minute x 1000.

- [1] **TURN INDICATORS** - Flashes with the indicator or hazard warning lamps (IGNITION ON).
- [2] **HEADLAMPS** - Shows that the main beam of the headlamps are ON.
- [3] **PATS** - If this symbol flashes continuously when the "START STOP SWITCH" is set to IGNITION ON the vehicle will stay immobilised.
- [4] **KEYLESS ENTRY AND START INDICATOR** - Comes ON if there is a fault with the keyless entry and start system.
- [5] **ECO DRIVING INDICATOR** - Comes ON when the vehicle is being driven economically.

Warning: If the ABS warning symbol stays ON, do not drive the vehicle. Have the system checked by an Aston Martin Dealer.

- [6] **ABS WARNING** - If this symbol stays ON or comes ON whilst driving there is a fault in the ABS control circuits. Continue driving only if there are no audible, visible or physical signs of degraded brake performance. Consult your Aston Martin Dealer as soon as possible if this symbol stays ON.

Warning: Do not drive the vehicle if the seat belt warning symbol stays ON. Have the system checked by an Aston Martin Dealer.

- [7] **DRIVER'S SEAT BELT WARNING** - This warning symbol will come ON and a chime will sound for 30 seconds if the driver's seat belt is not fastened when the vehicle has reached a speed of at least 20 km/h. Then, if the seat belt is still unfastened, the chime will sound in a different tone for a further 90 seconds.
- [8] **OIL PRESSURE WARNING** - Comes ON when the engine oil pressure falls below minimum. Do not continue driving if this symbol stays ON. Contact your Aston Martin Dealer immediately.
- [9] **SIDE LAMPS** - Shows that the side lamps, dip or main beams are ON.

[10]  **OPEN DOOR WARNING** - Indicates that a door is not fully closed.

Warning: *If the brake warning symbol stays ON, after fully releasing the park brake do not drive the vehicle. Have the system checked by an Aston Martin Dealer.*

[11]  **BRAKE WARNING** - When the "START STOP SWITCH" is set to IGNITION ON this symbol comes ON when the park brake is applied and goes OFF when the park brake is fully released. A buzzer will sound to indicate that parking brake is still engaged (with the vehicle having reached a speed of 5 km/h). If the symbol stays ON, after fully releasing the park brake, it shows that either the brake fluid level is low or that there is a fault in the brake system.

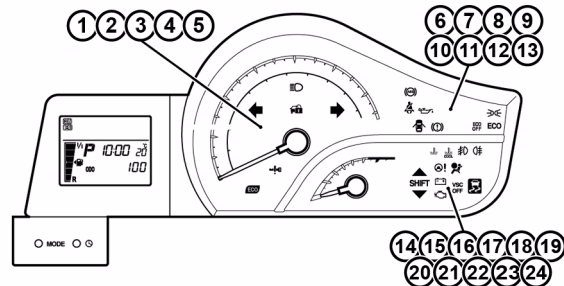

ECO
[12]  **OFF ECO MODE OFF** - Shows that the Stop & Start system is OFF.

[13]  **ECO MODE ON** - Shows that the Stop & Start system is ON.

[14]  **HIGH COOLANT TEMPERATURE** - Shows when the engine coolant is overheating. Do not continue driving if this symbol stays ON. Contact your Aston Martin Dealer immediately.

Warning: *Do not race a cold engine. Revving the engine before fully warmed up may cause severe engine and transaxle damage.*

[15]  **LOW COOLANT TEMPERATURE** - Shows that the engine coolant temperature is cool. Do not race the engine when this symbol is ON.

[16]  **FRONT FOG LAMP** - Shows that the front fog lamps are ON.

[17]  **REAR FOG LAMP** - Shows that the rear fog lamps are ON.

[18]  **GEAR SHIFT INDICATOR - VEHICLES WITH A MANUAL TRANSMISSION** - The Gear Shift Indicator display is a guide to help the driver achieve improved fuel economy and reduced exhaust emissions within limits of engine performance.

[19]  **ELECTRIC POWER STEERING WARNING** - Shows a fault in the Electric Power Steering (EPS) system.

Warning: Do not drive the vehicle if the SRS warning symbol stays ON. Have the system checked by an Aston Martin Dealer.

[20]  **SUPPLEMENTARY RESTRAINT SYSTEM** - When the "START STOP SWITCH" is set to IGNITION ON, this symbol comes ON for a few seconds as a readiness sign.

If it does not come ON, or if it does not go OFF after a few seconds, or if it comes ON whilst driving, the airbag self diagnostic system has detected a fault.

[21]  **CHARGING SYSTEM WARNING** - Indicates a fault in the vehicle's charging system. Do not continue driving if this symbol stays ON. Contact your Aston Martin Dealer immediately.

[22]  **VSC OFF VEHICLE STABILITY CONTROL** - When the Vehicle Stability Control (VSC) system is OFF this symbol will show as a warning that VSC and traction control is OFF. When VSC is ON this symbol will flash when there is a fault with the VSC system. Consult your Aston Martin Dealer as soon as possible.

[23]  **TRACTION CONTROL** - When Vehicle Stability Control (VSC) is ON this symbol will flash and an intermittent buzzer will sound when the VSC system is operating. When the VSC or traction control system is OFF this symbol will show as a warning that VSC or traction control is OFF.

[24]  **CHECK ENGINE** - Shows a fault in the engine management system. Continue driving only if there are no audible, visible or physical signs of degraded engine performance. Consult your Aston Martin Dealer immediately.

Warning Symbols

As the "START STOP SWITCH" is set to IGNITION ON, the electronic control units complete a self check. During these checks the following symbols will come ON for a few seconds.



Under normal circumstances most warning symbols will go OFF at the end of the individual system check if system checks are satisfactory.

Trip Computer

The trip computer presents the driver with a variety of driving-related information, including the time and the current outside temperature.

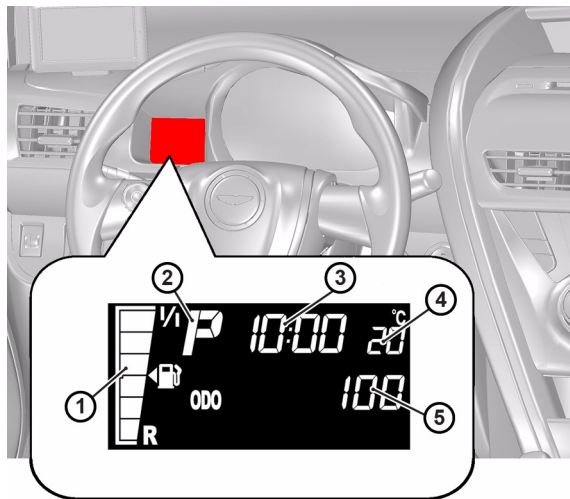

[1] FUEL GAUGE - Displays the quantity of fuel remaining in the tank.

The  **LOW FUEL WARNING** symbol comes ON when only approximately 5.9 litres of fuel is available.

 When filled with less than 10 litres per refuelling, the fuel gauge may not display accurately.

[2] SHIFT POSITION AND SHIFT RANGE/GEAR DISPLAY - Displays the shift position along with the currently selected shift range or gear.

[3] AMBIENT TEMPERATURE DISPLAY - Displays the outside air temperature.

The temperature range that can be displayed is from -40°C (-40°F) to 50°C (122°F).

[4] TRIP INFORMATION - Displays odometer, trip meter, fuel consumption, Stop & Start system operation time, Stop & Start system total operation time and other cruising-related information.

 The trip computer can be operated when the "ENGINE START STOP" switch is in IGNITION ON mode.

Switching the Display -

Display items can be switched by pressing the MODE button.

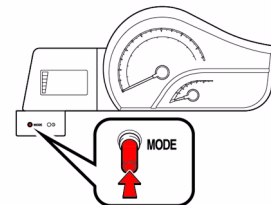

Odometer - Displays the total distance the vehicle has been driven.



Trip Meter A^{*1} - Displays the total distance the vehicle has been driven since the meter was last reset. ¹



¹ The function can be reset by pressing the MODE button for longer than one second when the trip meter A is displayed.

Trip Meter B^{*1} - Displays the total distance the vehicle has been driven since the meter was last reset. ₁



*1: Trip meters A and B can be used to record and display different distances independently.

Instrument Panel Light Control Display -

Displays the instrument panel light control display. ₂



Instantaneous Fuel Consumption -

Shows the Eco Driving Indicator Zone Display and the instantaneous fuel consumption (no reset).



- ₁. The function can be reset by pressing the MODE button for longer than one second when the trip meter B is displayed.
- ₂. Pushing and holding the MODE button for longer than one second will adjust the brightness of the instrument panel light when the tail lamps are on.

Average Fuel Consumption after Refuelling^{*2}

- Shows the Eco Driving Indicator Zone Display and the average fuel consumption since last reset. ₃



*2: When filled with less than 10 litres per refuelling, the “average fuel consumption after refuelling” may not be displayed accurately.

Stop & Start System Operation Time -

Displays the amount of time the engine was stopped due to operation of the Stop & Start system during the current trip.



- ₃. The function can be reset by pressing the MODE button for longer than one second when the average fuel consumption is displayed.

Stop & Start System Total Operation Time -

Displays the total amount of time that the engine has been stopped due to operation of the Stop & Start system since the system was last reset. ₄



Setting the Eco Driving Indicator Light -

The Eco Driving Indicator Light can be switched ON and OFF₅



- ₄. The function can be reset by pressing the MODE button for longer than one second when the Stop & Start system total operation time is displayed.
- ₅. The display can switched ON or OFF by pressing the MODE button for longer than one second.

Average Speed - Shows the average speed since last reset. ¹

Ambient Temperature - In the following situations, the correct outside temperature may not be displayed, or the display may take longer than normal to change.

- When stopped, or driving at low speeds (less than 20 km/h)
- When the outside temperature has changed suddenly (at the entrance/ exit of a garage, tunnel, etc.)



Eco Driving Indicator Zone Display

The range of accelerator pedal operation that will allow Eco-friendly operation (Eco driving) and the current accelerator opening are displayed. When the vehicle is operating within the Eco driving range, Eco Driving Indicator Light (1) illuminates. When the accelerator is depressed excessively and the indicator exceeds the Eco driving range, the right side of Eco Driving Indicator Zone Display (2) blinks and Eco Driving Indicator Light turns OFF (when driving in D).

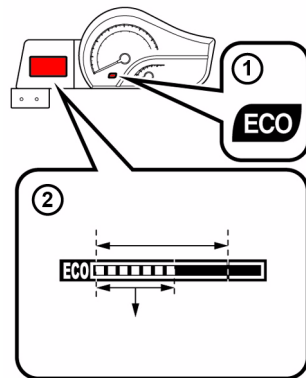

 At extremely low temperatures, allow the interior of the vehicle to warm up before using the liquid crystal information display. The information display monitor may respond slowly, and display changes may be delayed.

Setting the Clock

1. Press and hold the clock reset button to enter the adjustment mode for the clock.
2. Press the clock reset button to adjust the minutes.²
3. Press the clock reset button to adjust the hours.³

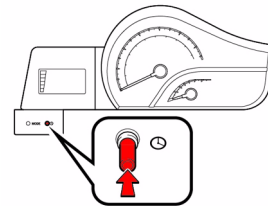

¹ The function can be reset by pressing the MODE button for longer than one second when the average speed is displayed.

² After adjusting the minutes, wait for five seconds to allow the minutes to be automatically input.

³ After adjusting the hours, wait for five seconds to allow the hours to be automatically input.

 If the clock reset button is pressed, the minute values will be rounded to the nearest hour. So, minute values from “:00” to “:29” are rounded down, and values from “:30” to “:59” are rounded up.

When disconnecting and reconnecting battery terminals the following information will be reset:

- Clock
- Trip meter
- Average fuel consumption after refuelling
- Stop & Start system operation time
- Stop & Start system total operation time
- Average speed

Centre Stack

- **HAZARD WARNING LAMP**
Press to set the hazard warning lamps to ON or OFF.
- **CLIMATE CONTROLS**
(Refer to ‘Climate Controls’, page 6.2)

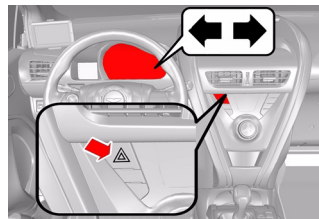

Centre Console

[1] VEHICLE STABILITY CONTROL (VSC) - The Vehicle Stability Control (VSC) system defaults to ON at each IGNITION ON. Press and release to switch to set the traction control to OFF. Press and hold for approximately three seconds to set traction control and VSC to OFF. Press and release to set VSC ON again (Refer to ‘Vehicle Stability Control’, page 5.8).

[2] AUXILIARY SOCKET - The auxiliary input socket can be used to connect a portable audio device and listen to it through the vehicle’s speakers (Refer to ‘Auxiliary Functions’, page 7.14).

[3] HEATED SEATS - Controls the operation of the seat heaters. Press and release the “L” or “R” switch to set the respective heater to ON. Press and release again to set the heater to OFF. (Refer to ‘Temperature Controlled Seats’, page 3.5).

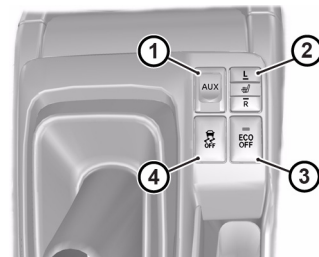

[4] STOP & START SYSTEM - VEHICLES WITH A MANUAL

TRANSMISSION - The Stop & Start System stops and restarts the engine according to the clutch pedal operation and gear position. Press and release to set the system to OFF. Press and release again to set the system to ON (Refer to 'Stop & Start System', page 5.9).

Ignition Control

To access vehicle functions and to start the engine the vehicle key must be present and the "START STOP SWITCH" must be switched to the ACCESSORY or IGNITION ON mode.

ACCESSORY Mode

Auxiliaries ON (audio, satellite navigation, available), steering lock OFF.

Press in the "START STOP SWITCH" until the indicator turns amber, and then release.

IGNITION ON Mode

The engine is started and all electrical components can be used.

Automatic Transmission:

Check that the shift lever is in P and fully press the brake pedal down.



Manual transmission: Check that the shift lever is in Neutral and fully press the clutch pedal down.

The indicator will turn green. Press in the "ENGINE START STOP" switch until the engine starts, and then release.

Preventing Unnecessary Battery Drain

If the "START STOP SWITCH" is left in the ACCESSORY mode, some vehicle circuits will stay ON and unnecessary current will be drawn from the battery.

Always return the "START STOP SWITCH" to OFF when ACCESSORY power is not required.

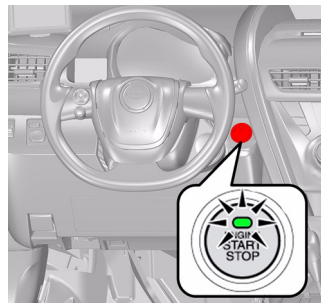

Stalk Controls

Left Side Stalk

Turn Signals - Press up for a right turn, press down for a left turn. Returns to the centre position on completion of a manoeuvre. Hold against spring pressure to show a lane change.

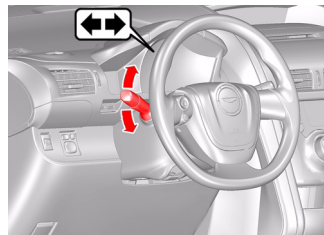

Headlamp Switch - The headlamps can be operated manually or automatically.

[1] OFF - All lamps are OFF.



[2]  - The front position, tail, licence plate and instrument panel lamps turn ON.

[3]  - The headlamps and all of the lamps listed above turn ON.

[4] AUTO - The headlamps, front position lamps and other lamps turn ON and OFF automatically when the "ENGINE START STOP" switch is in IGNITION ON mode.

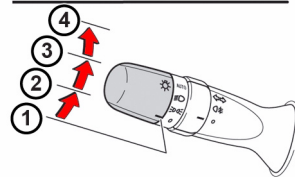
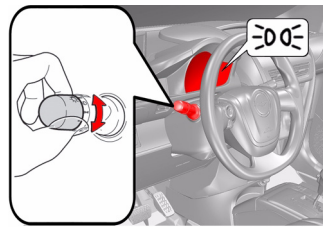
When the headlamp switch is set to **AUTO**: The headlamps and all lamps turn OFF automatically if the "ENGINE START STOP" switch is switched to ACCESSORY mode or turned OFF and the driver's door is opened.



To turn the lamps ON again, switch to IGNITION ON mode, or turn the headlamp switch off once and then back to  or .

The headlamp control sensor may not function properly if an object is placed on the sensor, or if anything that is affixed to the windscreen.

Doing so interferes with the sensor detecting the level of ambient light and may cause the automatic headlamp system to malfunction.

Main and Dipped Beam

With the headlamps ON, push the lever forwards and latch for main beam (1). Pull the lever towards you again (2) and latch to return to dipped beam. Pull the lever towards you and release it without latching to flash main beam ON and OFF.

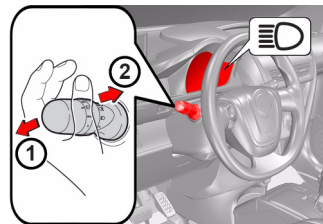

Front and Rear Fog Lamps

Switch - The fog lamps improve visibility in difficult driving conditions, such as in rain or fog. The front fog lamps can be used when the headlamps or front position lamps are turned ON. The rear fog lamps can be used when the front fog lamps are turned ON.

[1] - OFF.

[2] - Front fog lamps ON.

[3] - Both front and rear fog lamps ON. (Rotating the switch ring again only turns the rear fog lamp OFF.)

Releasing the switch returns the ring to the $\#D$ position.

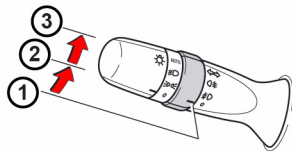
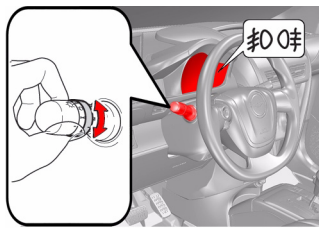
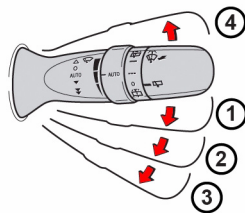
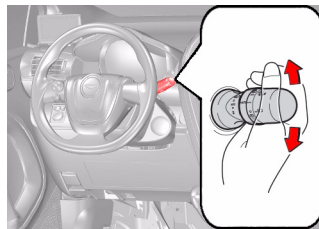
**Right Side Stalk****Windscreen Wiper Control**

With **AUTO** selected, the wipers will operate automatically when the sensor detects falling rain. The system automatically adjusts the wiper timing in accordance with the rain volume and the vehicle speed.

[1] - Rain-sensing Wipe.

[2] - Normal Speed Wipe.

[3] - Fast Wipe.

[4] - Demand Wipe.

[5] - Sensor Sensitivity (High).

[6] - Sensor Sensitivity (Low).

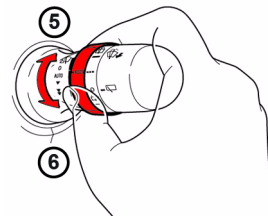

Windscreen Washer

Control - Pull the lever towards you to operate the windscreen washers. Operation continues until the lever is released. When released the washers stop immediately but the wipers continue for a few strokes.

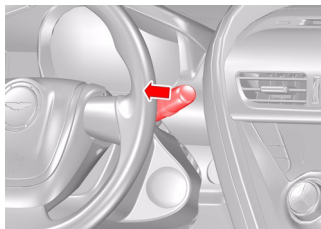

If used during normal wiper operation, the wipers operate continually irrespective of the washer operation.

Speed Sensitive Wipe - Even when the wipers are not in **AUTO** mode, wiper operation varies depending on vehicle speed when the washer is being used.

Tailgate Window Wiper Control -

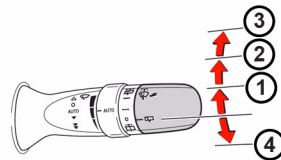
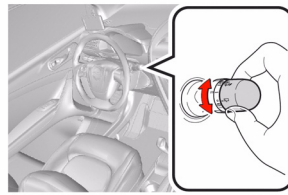

- [1] - Intermittent Wipe.
- [2] - Normal Speed Wipe.
- [3] - Washer/wipe Dual Operation.
- [4] - Washer Operation.

Vehicle Horn

To sound the horn press the centre pad of the steering wheel on or close to the  symbol.

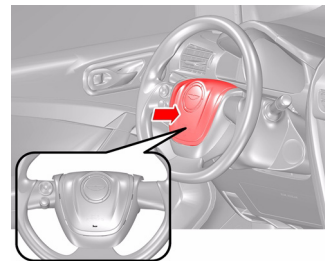



ASTON MARTIN



ASTON MARTIN



ASTON MARTIN

Driving

Driving Safety.....	5.2	Park Brake.....	5.7
Starting the Engine	5.2	Vehicle Stability Control	5.8
Automatic Transmission.....	5.4	Stop & Start System	5.9
Manual Transmission.....	5.5	Fuel Filling.....	5.11
Footbrake.....	5.6	Catalytic Converters	5.12
Anti-Lock Braking System	5.6	Rear Parking Assist.....	5.13
		Driving Techniques	5.13

Driving Safety

- Always wear your seat belt
- Never drive under the influence of alcohol or drugs
- Always obey all speed and traffic laws and regulations. Never drive faster than the posted speed limit or than conditions allow
- Be particularly careful driving on slippery or wet surfaces
- Follow the maintenance schedule approved in this guide

Starting the Engine

⚠ Warning: Always start the engine whilst sitting in the driver's seat. Do not depress the accelerator whilst starting the engine under any circumstances. Doing so may cause an accident resulting in death or serious injury.

⚠ Do not race a cold engine. Revving the engine before fully warmed up may cause severe engine and transaxle damage.

⚠ Do not press the "START STOP SWITCH" whilst driving. If the "START STOP SWITCH" is pressed in and released the engine will stop.

📖 Make sure that you are wearing appropriate footwear to efficiently operate the control pedals. Make sure that pedal movement is not restricted by floor mats or other objects trapped beneath pedals.

The keyless entry and start system allows the vehicle to be started without the need of a mechanical key. However, the vehicle key must be located inside the passenger compartment for the system to operate. (Refer to 'Keyless Entry and Start', page 2.2)

With the vehicle key on your person, check that the park brake is applied.

Automatic Transmission: Check that the shift lever is in P and fully press the brake pedal down.

Manual transmission: Check that the shift lever is in Neutral and fully press the clutch pedal down.

The "ENGINE START STOP" switch indicator turns green. If the indicator does not turn green, the engine cannot be started.

Press the "ENGINE START STOP" switch.

The engine can be started from any mode. ¹

When the "ENGINE START STOP" switch indicator flashes in amber the system may be malfunctioning. Have the vehicle inspected by an Aston Martin Dealer immediately.

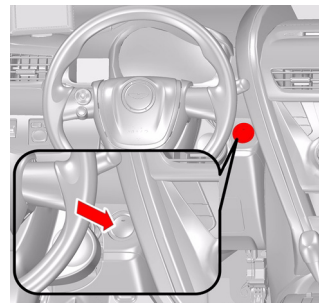

¹ The engine will crank until it starts or for up to 30 seconds, whichever is less. If you press and hold the "ENGINE START STOP" switch, the engine will keep cranking for a maximum of 30 seconds.

Changing “ENGINE START STOP” switch mode

Modes can be changed by pressing the “ENGINE START STOP” switch with the brake pedal (vehicles with an automatic transmission) or clutch pedal (vehicles with a manual transmission) released. (The mode changes each time the switch is pressed.)

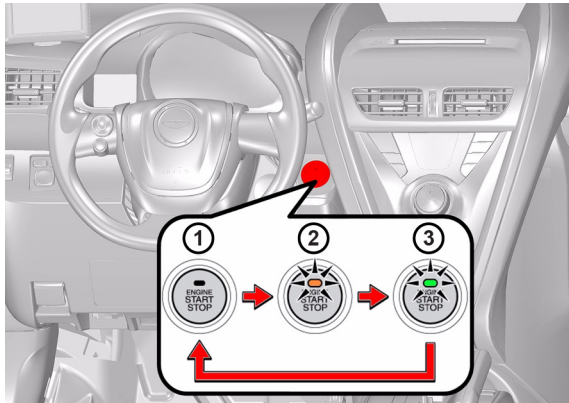

[1] OFF - Emergency flashers can be used.

 *For vehicles with an automatic transmission, if the shift lever is in a position other than P when turning off the engine, the “ENGINE START STOP” switch will be turned to ACCESSORY mode, not to OFF.*

[2] ACCESSORY MODE - Some electrical components such as the audio system can be used. The “ENGINE START STOP” switch indicator turns amber.

[3] IGNITION ON MODE - The engine is started and all electrical components can be used. The “ENGINE START STOP” switch indicator turns green.

Steering Lock Motor Overheat Prevention

If the engine is started and stopped repeatedly in a short time, operation of the steering lock motor is restricted to prevent overheating. If this occurs, wait momentarily without operating the “ENGINE START STOP” switch. The system will return to its normal condition in approximately 10 seconds.

Starting From Cold

The Engine Control Module (ECM) automatically compensates for cold or warm start conditions and makes appropriate adjustments to the fuel and air mixture and ignition timing.

Stopping the Engine

Press the “ENGINE START STOP” switch. The engine will then stop.

Auto Power OFF Function

For vehicles with an automatic transmission, if the vehicle is left in ACCESSORY mode for more than an hour with the shift lever in P, the “ENGINE START STOP” switch will automatically turn OFF.

For vehicles with a manual transmission, if the vehicle is left in ACCESSORY mode for more than an hour, the “ENGINE START STOP” switch will automatically turn OFF.

Fault Modes

If the keyless entry and start system cannot detect the vehicle key, the  symbol in the instrument cluster will come ON and a combination interior and exterior buzzers will sound.

- **Interior buzzer sounds once** - The vehicle key is outside of the detection area when the “ENGINE START STOP” switch is pressed.
Confirm the location of the vehicle key.
- **Interior buzzer sounds once, exterior buzzer sounds three times** - A door, other than the driver's door, has been opened and closed with the “ENGINE START STOP” switch in any other mode than OFF with the vehicle key outside of the detection area.
Confirm the location of the vehicle key.

If the  symbol stays ON consult your Aston Martin Dealer.

Automatic Transmission

Gearshifts are made by shifting the shift lever between Park, Reverse, Neutral, Drive and the engine braking gears (S and B). Whilst driving forward gearshifts are made automatically according to various driving parameters, i.e. road speed, current selected gear and accelerator demands. When the vehicle is stationary the transmission will select first gear, ready to move off immediately when the accelerator is pressed.

The trip computer shows the current gear selection P, R, N, D, etc.,

Park

Park should be used when starting the engine or when leaving the vehicle parked. The transmission will mechanically lock. When park is selected, **P** will show in the trip computer.

 **Always make sure that the park brake is ON when the vehicle is in Park.**

 *It is not possible to select Park above 2 km/h.*

Reverse

When stationary and with the footbrake applied, select Reverse. When Reverse is selected, **R** will show in the trip computer and a warning will be heard.

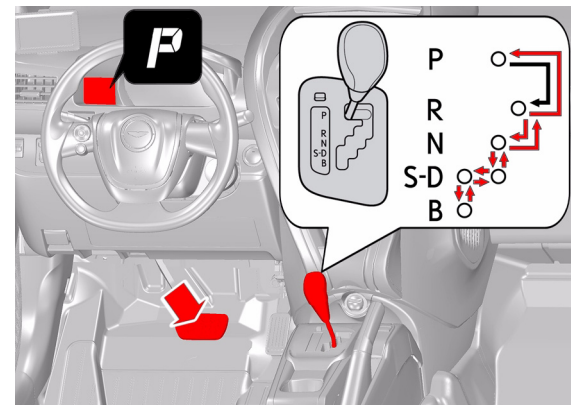

Manual Transmission

Neutral

When stationary and with the footbrake applied, select Neutral. When Neutral is selected, **N** will show in the trip computer.

Drive

When stationary and with the footbrake applied, select forward gears. When Drive is selected, **D** will show in the trip computer.

Sport

To increase the responsiveness of acceleration and braking select Sport. When Sport is selected, **S** will show in the trip computer.

Braking

When engine braking is required, (for example, during a long or steep hill descent) select Braking. When Braking is selected, **B** will show in the trip computer.

The manual transmission features a six speed gearbox.

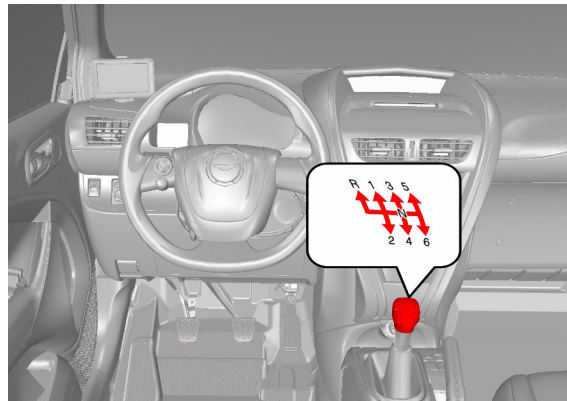

To select reverse gear, move the gear lever to the R position whilst lifting up the ring section.

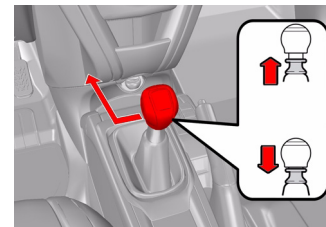

Footbrake

The footbrake operates through a vacuum boosted, dual (diagonal split) circuit, hydraulic system incorporating an Anti-lock Brake System (ABS).

⚠ Warning: In the event of a brake failure bring the vehicle to a halt as soon as it is safe to do so. Do not continue to drive.

⚠ If vacuum boost fails or one circuit fails the footbrake will still operate but with greater pedal pressure, increased pedal travel and longer stopping distances.

⚠ After a long drive over salted or gritted roads or if driving in heavy rain, through water or a vehicle wash, the braking action may be delayed and increased braking pressure may be required.

 Vacuum boost is only available whilst the engine is running.

Brake Warnings

⚠ Warning: If the brake warning symbol comes ON, you should immediately be prepared for possible increased stopping distances and possible partial failure of the braking system.

Whilst driving, if the brake warning symbol comes ON, it shows either that:

- The park brake is not fully released
- The brake fluid level has fallen below an acceptable level
- There is a fault in the brake system

Stop, as soon as possible in a safe and convenient place. Apply the footbrake and make sure that the park brake is fully released. If the park brake is fully released and the warning symbol stays ON, **do not drive the vehicle**. Contact the nearest Aston Martin Dealer. It is essential that the brake system is checked immediately, preferably by an Aston Martin Dealer.

Anti-Lock Braking System

The Anti-lock Braking System (ABS) helps prevent the road wheels from locking and skidding during emergency braking. This also assists the driver in maintaining steering and directional stability.

If, in an emergency braking situation, the braking force applied begins to exceed the tyre to road adhesion, the ABS operates to prevent the road wheels locking. When this happens a pulsating effect is felt through the brake pedal. This is a normal ABS effect.

Safety

In all cases it is always the driver's responsibility to drive safely according to the law and with due regard to prevailing conditions. The fact that a vehicle is equipped with ABS must never allow the driver to be tempted into taking risks which could affect his or her safety or that of other road users.

The addition of ABS cannot overcome the consequences of trying to stop in too short a distance, cornering at too high a speed, or the risk of aquaplaning (where the tyres are prevented from contacting the road surface by a layer of water).

The driver should always take road conditions into account. A slippery road surface always requires more braking distance for a given speed, even with ABS. Possible extensions of stopping distance compared to locked wheels may occur during ABS operation on slushy snow, gravel, sand or certain heavily corrugated or ridged warning sections of road surfaces.

If any braking system malfunction occurs, immediately have the Braking and ABS systems checked by your Aston Martin Dealer.

ABS Warning

⚠ Warning: If the ABS warning symbol comes ON, you should be aware that wheels could lock during extreme braking or when braking on slippery surfaces.

ABS is monitored for correct operation whilst the ignition is ON. If a fault is detected, the ABS warning symbol in the instrument cluster will come ON and the ABS will be partly or fully OFF. Normal braking will continue to function without ABS.

In the event of an ABS fault, consult your Aston Martin Dealer immediately.

Park Brake

⚠ Do not rely on the park brake to hold the vehicle stationary if the brake system warning symbol is ON or flashing. Contact your Aston Martin Dealer.

Apply and Release the Park Brake

⚠ Always fully apply the park brake before leaving the vehicle.

To apply the park brake:

With the vehicle stationary, press the footbrake pedal firmly down. Keep the pedal pressed down and pull the park brake lever up until resistance is felt. At this point depress the park brake button and continue to pull the park brake lever up to its fullest extent. Release the button and allow the lever to lower. At this time, the park brake warning symbol in the instrument cluster will come ON (if the ignition is ON) when the park brake is fully applied. The stop lamps will not come ON.

To release the park brake:

With the vehicle stationary, press the footbrake pedal firmly down. Keep the pedal pressed down and pull the park brake lever up until resistance is felt (1). Pull up against the resistance and depress the release button (2). Keep the button depressed and push the lever down (3). If the park brake lever is not fully OFF, the park brake warning symbol will stay ON.

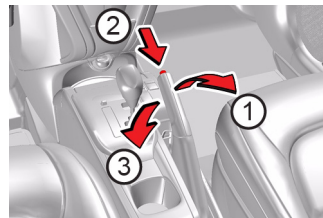

⚠ The park brake operates on the rear wheels of the vehicle. Secure parking of the vehicle is dependent on being on a hard and stable surface.

Park Brake Operation whilst Moving

! *Driving the vehicle with the park brake applied or repeated use of the park brake to slow the vehicle can cause serious damage to the brake system.*

A warning tone will sound to indicate that the parking brake is still engaged when the vehicle has reached a speed of 5 km/h.

Vehicle Stability Control

! *Warning: It is the driver's responsibility to drive safely according to the law and with due regard to prevailing conditions.*

! *Warning: Vehicle Stability Control (VSC) must never let the driver be tempted into taking risks which could affect his or her safety or that of other road users. VSC cannot overcome consequences of applying too much engine power for prevailing conditions.*

Vehicle Stability Control (VSC) is a system designed to enhance driving safety by improving the vehicle handling when the tyres are at the limits of their grip capabilities. This is achieved through adjusting steering torque and strategic application of the brakes at individual wheels.

Driver Interface and Control

! *If repair or replacement of the steering or other surrounding equipment is necessary, always refer to your Aston Martin Dealer. If the centre position of the steering deviates, the VSC may not operate correctly because there is a sensor in the steering system which detects steering wheel position.*

! *The VSC system may not operate correctly when using tyre chains or a temporary spare tyre.*

! *Use tyres of the same manufacturer, brand, tread pattern and correct size specified for this vehicle on all four road wheels. Do not mix worn tyres.*

VSC has three modes of operation:

ON - The VSC system sets to ON each time the engine is started. VSC is controlling steering torque and applying strategic application of the brakes at individual wheels.

Whilst the VSC system operates to correct the vehicle stability the

VSC symbol , on the instrument cluster, will flash and an intermittent buzzer will sound.

TRACTION CONTROL OFF -

Press the VSC button to turn the traction control OFF. The



 symbol will show in the instrument cluster.



TRACTION CONTROL and VEHICLE STABILITY CONTROL OFF -

Press and hold the VSC button for three seconds and release

to set the VSC to OFF. The

 and  symbols will show in the instrument cluster. VSC is no longer controlling steering torque and applying strategic application of the brakes at individual wheels.



At any time whilst in either of the two modes, press and release the VSC button to start VSC.

If traction control cuts in when driving on extended icy or slippery surfaces, reduce engine power as necessary until the  symbol goes OFF.

Traction control is always ON when VSC is ON.

Fault Signs

If there is a malfunction in the VSC control system the  symbol in the instrument cluster will come ON and the ^{VSC}OFF symbol in the instrument cluster will flash.

Consult your Aston Martin Dealer as soon as possible.

⚠ Keep the gear lever in Neutral and apply the brake pedal or parking brake for safety whilst the engine is stopped due to the Stop & Start system (whilst the ECO indicator is ON). Unexpected accidents may occur due to the automatic engine start function.

Do not leave the vehicle whilst the engine is stopped due to the Stop & Start system (whilst the ECO indicator is ON). Unexpected accidents may occur due to the automatic engine start function.

Make sure that the engine is not stopped by the Stop & Start system whilst the vehicle is in a poorly ventilated area. The engine may restart due to the automatic engine start function, causing exhaust gases to collect and enter the vehicle and resulting in death or a serious health hazard.

The Stop & Start system stops and restarts the engine according to the clutch pedal operation for stopping and starting the vehicle.

The Stop & Start system operation time and Stop & Start system total operation time are displayed on the trip computer. (Refer to 'Trip Computer', page 4.6)

Stopping the Engine

With the clutch pedal fully depressed, stop the vehicle. Then shift the gear lever to Neutral.

Release the clutch pedal.

The engine will stop and the ECO indicator will come ON.

Restarting the Engine

Check that the gear lever is in Neutral and depress the clutch pedal. The engine will restart, the ECO indicator will go OFF and the ECO OFF indicator will come ON (in this situation, releasing the clutch pedal will not stop the engine again).



When the vehicle begins to move, the ECO OFF indicator will come ON.



Disabling the Stop & Start System

Press the ECO OFF switch to disable the Stop & Start system.

- The indicator on the switch will come ON
- At each stop, even when the clutch operation is performed to stop the engine, the engine will not stop and the ECO OFF indicator will come ON



- Pressing the switch again turns OFF the indicator on the switch and re-enables the Stop & Start system

Features of the Stop & Start System

Automatic Reactivation

If the Stop & Start system is disabled by the ECO OFF switch, it will be automatically re-enabled once the “ENGINE START STOP” switch is turned to the OFF mode for more than three seconds before being returned to the IGNITION ON mode.

The Stop & Start System Protection Feature

When excessively loud sound is being projected by the audio system, the audio system may be automatically switched OFF in order to maintain power for the Stop & Start system function.

If this occurs, turn the “ENGINE START STOP” switch to the OFF mode for more than three seconds before returning to ACCESSORY or IGNITION ON mode.

Steering Wheel Operation

When the engine is stopped by the Stop & Start system, the steering wheel may become heavier than when driving.

Bonnet

If the bonnet is opened whilst the engine is stopped by the Stop & Start system, the engine cannot be restarted by the Stop & Start system or by the automatic engine start function. The engine must be restarted using the "ENGINE START STOP" switch.

Fault Signs

If the engine is stopped by the Stop & Start system and either of the following actions is performed, the ECO indicator will flash and a buzzer will sound a warning:

- The driver's door is opened
- The gear lever is shifted into a position other than Neutral with the clutch pedal released

If the ECO indicator continues to flash the Stop & Start system may be malfunctioning. Contact an Aston Martin Dealer.

Fuel Filling

Before refuelling the vehicle turn the "ENGINE START STOP" switch to OFF and make sure that the doors and windows are closed. To open the fuel tank cap pull up the fuel filler door opener (1 (located to the left of the driver's seat)).

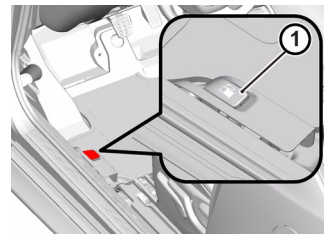

Turn the fuel tank cap slowly to open it.

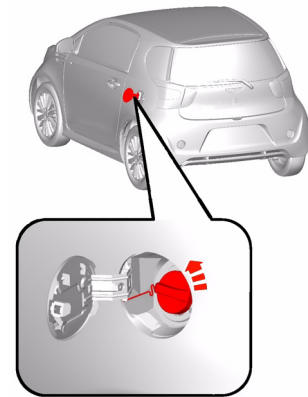

Hang the fuel tank cap on the back of the fuel filler door.

 The fuel tank filler neck has a restricted opening which will only accept the fuel supply nozzle of unleaded fuel pumps.

The fuel system will not let the fuel tank overfill but there will be times when the fuel nozzle will shut OFF prematurely. If this happens only try to fill the fuel tank one more time, continued attempts will result in fuel spillage. Wait 10 seconds before removing the refuelling nozzle.

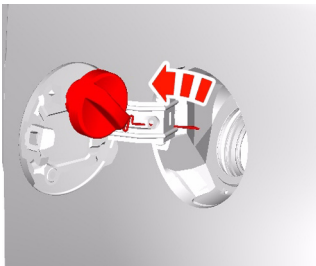

When replacing the fuel tank cap, turn it until a clicking sound is heard.¹

Fuel Cut-OFF

In the event of a vehicle accident the vehicle electronics will enter crash mode. Power to the fuel pumps will stop, thereby reducing fire risk.

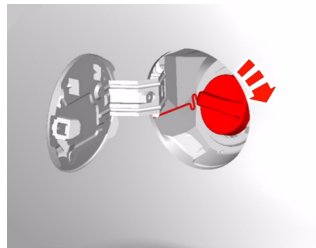

Catalytic Converters

 **Warning:** Do not park over dry grass, leaves or other combustible material. Significant fire risk exists because of residual heat in the catalytic converters.

 **Warning:** Do not drive through deep water. Rapid cooling of catalysts may cause them to break up.

Catalytic converters convert harmful exhaust gasses into less noxious substances and so reduce environmental pollution. They operate at high temperatures and continue to radiate a considerable amount of heat after the ignition has been set to OFF.

Leaded fuel will cause irreparable damage to catalytic converters. If leaded fuel is inadvertently added to the fuel tank **do not start the engine, do not drive the vehicle**. Contact your Aston Martin Dealer immediately.

¹. After releasing your hand, the cap will turn slightly to the opposite direction.

Rear Parking Assist

(If installed on your vehicle)

⚠ Warning: Rear parking assist does not replace need for total vigilance and caution when parking or reversing.

⚠ When parking or reversing make full use of rearward vision and all mirrors to be aware of persons or objects in the vicinity of the vehicle. Take appropriate measures to protect them from danger.

⚠ In heavy rain or similar adverse conditions, the rear parking assist sensors may not always be able to accurately measure distance to close objects. A fully laden vehicle or irregular obstacles may also cause inaccurate measurements.

Rear parking assist aids in detecting obstructions as the vehicle is reversed towards them. The system is ON when reverse gear is selected. When the system is operating an intermittent 'beep' signal will be heard. The 'beep' frequency increases in pitch and persistence as the vehicle reverses to an obstruction.

 *The 'beeps' start at approximately 1.7 m from any obstruction. The 'beep' becomes continuous at distances less than 30 cm.*

For reliable operation, the parking sensors should be kept free from ice, frost and grime.

Driving Techniques

Procedures for driving this vehicle may be unfamiliar to many new owners. To make sure that you have a safe and enjoyable entry into this new phase of Aston Martin motoring please take time to safely acquire the necessary new driving skills.

Wet Conditions

When driving in wet conditions, water can build up under your tyres so that they ride on a layer of water. This is called aquaplaning or hydroplaning. When this happens, you have little or no control.

Aquaplaning is more prone to happening at higher road speeds if there is a lot of water on the road and particularly if the tyres are also under inflated or approaching minimum tread depth.

It is important to take bends or curves at a safe, reasonable speed, particularly when driving on wet or slippery road surfaces.

Slow down when it is raining.

Driving Through Deep Water

⚠ If in any doubt whether to drive through deep water, always take the side of caution to avoid potentially costly damage to the vehicle's engine or other essential systems.

If driving on flooded roads, through deep or standing water is unavoidable, proceed with extreme caution, especially when the depth is not known. Never drive in water deeper than the lower edge of the front bumper. Water can be splashed up into the engine air intake located in the front upper grille and cause extensive damage to the engine or the vehicle may stall.

When driving through water, traction or brake capability may be limited. Once through the water, always dry the brakes by driving slowly whilst applying light pressure on the brake pedal.

 *Waves caused by other vehicles or natural causes can also splash water in the engine air intake.*

Running-In

To extend the life of this vehicle, it is recommended to observe the following precautions:

For the first 300 km:

- Avoid sudden stops

For the first 1600 km:

- Do not drive at extremely high speeds
- Avoid sudden acceleration
- Do not drive continuously in the low gears
- Do not drive at a constant speed for extended periods



ASTON MARTIN



ASTON MARTIN

Climate Control

Operating Tips	6.2
Climate Controls	6.2
Airflow Modes.....	6.4
Automatic Operation	6.6
Manual Operation.....	6.6



Operating Tips

- A solar sensor is installed on top of the instrument panel, this should not be covered when driving
- The intake grille of the in-vehicle temperature sensor is located behind the instrument cluster
- Moisture which forms on the evaporator in the air conditioning unit is discharged via a drain tube onto the road. After stopping, small puddles of water may form underneath the vehicle. This is normal and does not show a system malfunction
- Operate the climate control system with the engine operating
- Clear all obstructions like leaves, snow and ice from the bonnet and the air inlet in the front grille to improve the system efficiency
- Windows can fog up easily in humid weather. Use the climate control system to demist the windows
- To help demist the windows, operate the air conditioner to dehumidify the air
- Use the 'outside air' position in normal conditions. The 'recirculated air' position should be used temporarily when driving on dusty roads or for quick cooling or heating of the interior
- If the vehicle has been parked in direct sunlight during hot weather, open the windows to let warm air escape, then close the windows and operate the climate control system
- Operate the climate control system at least once a month to keep internal parts lubricated
- Have the climate control system checked before the weather gets hot. If the climate control system is low on refrigerant or has a malfunction, consult your Aston Martin Dealer
- This vehicle is equipped with a pollen filter. It is necessary to change the filter periodically as shown in the scheduled maintenance. Consult your Aston Martin Dealer

Climate Controls

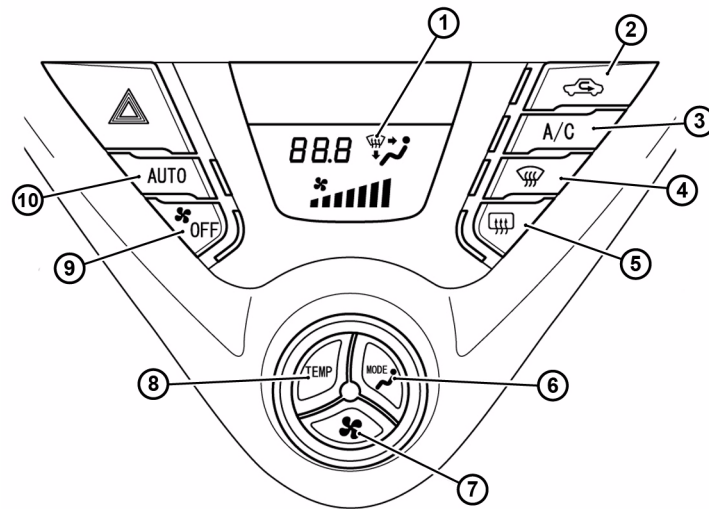



[1] **DISPLAY** - Shows temperature settings, fan speed and airflow information.

⚠ Warning: Do not select recirculated air in cold or rainy weather, it can cause the interior glass to mist up.

[2]  **AIR CIRCULATION** - Controls the source of air entering the vehicle. Press to select recirculated air (button LED ON). Press again to select outside air as source.

Use the recirculated air position when going through tunnels, driving in congested traffic (high engine exhaust areas) or when maximum cooling is required. On start up the default position is outside air as source. Use this position for normal conditions and demisting.

[3]  **A/C** - When in manual mode press and release to set the air conditioning ON or OFF.

[4]  **WINDSCREEN DEMIST** - Press for maximum defrost or demist ON or OFF. Outside air intake is automatically selected and air conditioning is automatically started.

[5]  **HEATED REAR WINDOW** - Press to operate the rear window heater. Goes OFF after 15 minutes if not manually set to OFF. When the heated rear window is ON the door mirror heaters will also work for 15 minutes, then go OFF.

[6]  **AIRFLOW** - Press to select and then turn the control dial to change the airflow. The selected air flow mode is shown on the **DISPLAY**.

[7]  **FAN SPEED** - Press to select and then turn the control dial to set the required fan speed (clockwise for fast speed and counterclockwise for low speed). The fan speed is shown on the **DISPLAY**.

[8]  **TEMPERATURE** - Press to select and then turn the control dial to set the required fan speed (clockwise for fast speed and counterclockwise for low speed). The temperature is shown on the **DISPLAY**.

[9]  **FAN OFF** - Press to turn the fan OFF.

[10]  **AUTOMATIC CONTROL** - Press for automatic climate control operation.

Airflow Modes

Four airflow modes are available.

When the mode is set to , air flows to the upper body.

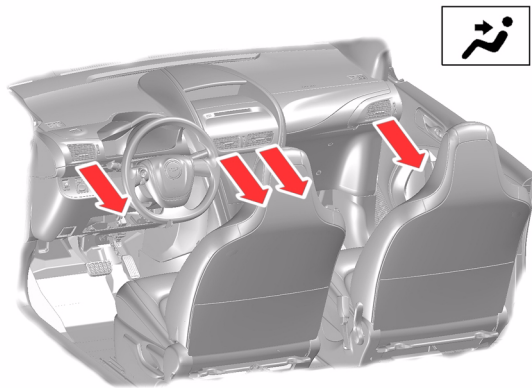

When the mode is set to , air flows to the upper body and feet.

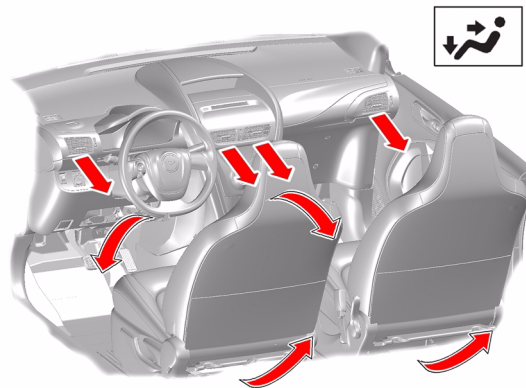

When the mode is set to , air flows mainly to the feet.

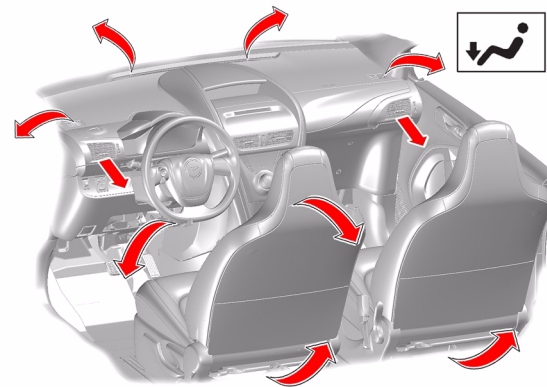

When the mode is set to , air flows to the feet and the windscreen demist operates.

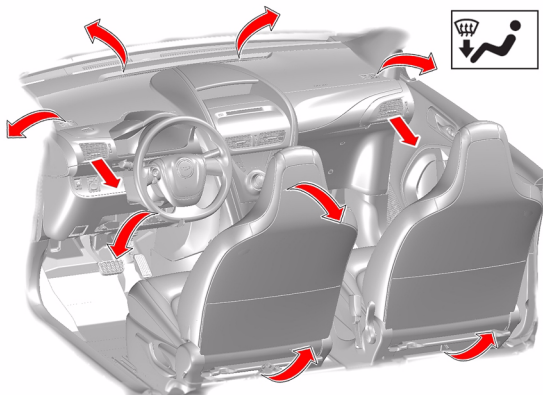

Adjusting the Vents

To adjust the right and left side air flow vents:

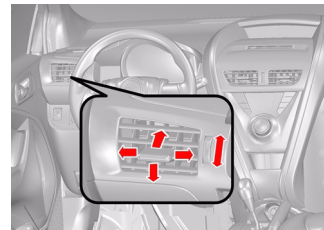

To adjust the centre air flow vents:

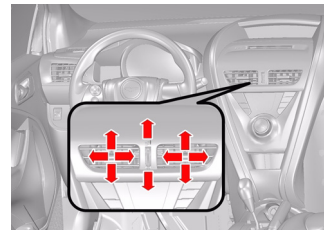

Solar and Temperature Sensors

The automatic air conditioner function measures inside and outside temperatures, and sunlight. It then sets the interior temperature accordingly. To maintain effective operation do not obscure the following sensors:

[1] - Solar sensor

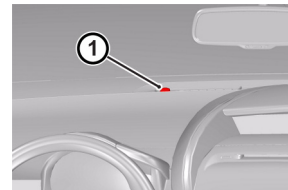

[2] - In-vehicle temperature sensor

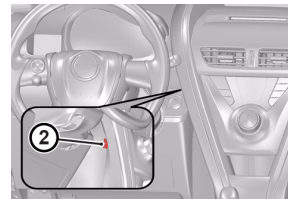



Automatic Operation

Press the **AUTO** button. Using the **TEMPERATURE** button and the control dial set the required in-vehicle temperature (read the actual temperature setting in the top left of the **DISPLAY**). The **A/C** button LED will come ON.

Adjustments to fan speed, air flow and air recirculation will be made automatically according to the set temperature, interior and exterior conditions.

 *Maximum fan speed will not be available until the engine has reached its normal operating temperature.*

 *When using the air conditioner, mist may come out from the vents. This is not a sign of trouble but a result of humid air being suddenly cooled.*

 *If resetting climate control functions other than the fan speed, the fan speed will stay set as in automatic mode. Adjustments to the fan speed will cancel Auto Mode.*

Defrost and Demist

Press the **WINDSCREEN DEMIST** button. The outside air intake is automatically selected, the temperature is set to maximum and A/C is started.

To cancel Automatic defrost or demist either:

- Press **WINDSCREEN DEMIST** again

or

- Press **AUTO**

or

- Press any of the airflow mode buttons

Manual Operation

Set the required:



- Fan speed
- Temperature
- Air flow

If dehumidifying is required, press the **A/C** button (button LED ON). To stop dehumidifying press **A/C** A/C button (button LED OFF).

 *When using the air conditioner, mist may come out from the vents. This is not a sign of trouble but a result of humid air being suddenly cooled.*

 *Setting the temperature to maximum high or low will not provide the required temperature at a faster rate. To prevent cool air blowing from the vents when heating immediately after starting a cold engine, the amount of airflow is reduced until the air warms up.*

 *The vehicle heater will continue to produce the selected temperature regardless of in-vehicle conditions.*

 *When maximum cooling is required, press the **TEMPERATURE** button and set the control dial to the extreme cold position and press the **AIR CIRCULATION** button to the recirculated air position () will show in the **DISPLAY**), then set a fast fan speed.*

Defrost and Demist

! *To defrost or demist the windscreen on vehicle start up in extreme cold weather conditions, operate the engine at 1500 rpm. Always make sure that the transmission is in Park for vehicles with an automatic transmission or Neutral for vehicles with a manual transmission, and that the park brake is applied.*

Press the **A/C** button. Press the **AIRFLOW** button and use the control

dial to select  airflow mode.

Set the required:

- Temperature
- Fan speed

 *If the engine is cold the air conditioning will not start up until the engine has started to warm up.*

 *For maximum defrost or demist set the temperature and fan speed to maximum.*



ASTON MARTIN



ASTON MARTIN



ASTON MARTIN



ASTON MARTIN



ASTON MARTIN



Audio

Audio Essentials.....	7.2
Audio Controls	7.2
Radio Functions	7.4
Radio Data System	7.5
Enhanced Other Networks	7.6
CD Player	7.7
MP3/WMA Player	7.10
Auxiliary Functions.....	7.14
Audio Menus	7.14

Audio Essentials

Standard Audio

Radio - AM and FM radio. 6 AM and 18 FM presets are available.

CD - CD player.

Auxiliary Input - Connection port.

Speakers

[1] - Two door-mounted speakers.

[2] - Two door-mounted tweeter units.

[3] - Two speakers, mounted in the lower rear trim panels.



Audio Controls

Operation

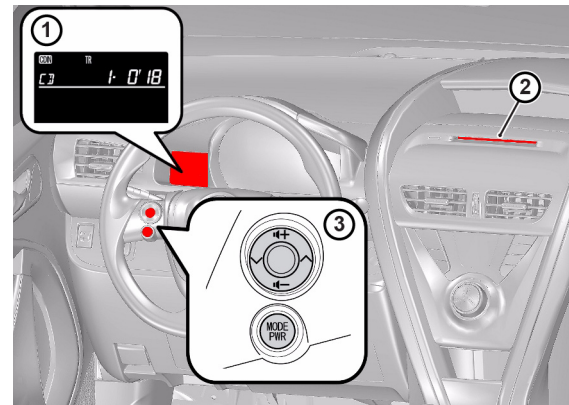

[1] - Audio display.

[2] - CD slot.

[3] - Audio switches.

The audio system is available when the "ENGINE START STOP" switch is in ACCESSORY or IGNITION ON mode.

If the audio system is ON when the "ENGINE START STOP" switched to OFF, it will automatically start the next time the "ENGINE START STOP" switch turned to ACCESSORY or IGNITION ON mode.

Press  to set the audio system to ON.

The audio system can be turned OFF by holding the switch down until two beeps are heard.

 *When the audio system is set to ON the volume will be at the same level it was when the audio system was set to OFF.*

Sound Source

To select the available audio sound sources press the  button repeatedly to navigate through the sound source choices.

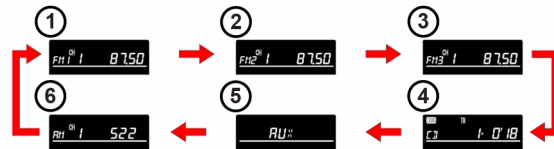

- [1] - FM1
- [2] - FM2
- [3] - FM3
- [4] - CD
- [5] - AUX
- [6] - AM





 *CD mode cannot be selected if there is no CD inserted.*



AUX mode cannot be selected if there is no portable audio device connected.

Menus

To access the audio menu press and hold  until a beep is heard. **MENU** appears in the top left-hand corner of the **DISPLAY**. Then press repeatedly until the required option is shown.

Aston Martin Audio Sound Settings

To access sound settings press and hold  until you hear a beep to enter the audio menu. **MENU** appears in the top left-hand corner of the **DISPLAY**. Then press repeatedly until the required sound setting is shown. Press "+" or "-" on  to adjust the level.

Sound Quality Mode	Mode Displayed	Level	Press 	Press 
Bass*	BAS	-5 to 5	Low	High
Treble*	TRE	-5 to 5		
Front/Rear Volume Balance	FAD	F7 to R7	Shifts to Rear	Shifts to Front
Left/Right Volume Balance	BAL	L7 to R7	Shifts to Left	Shifts to Right

* The sound quality level is adjusted individually in each radio mode, CD mode or AUX mode.

Radio Functions

Tuning the Radio

Press and hold  until a beep is heard. **MENU** appears in the top left-hand corner of the **DISPLAY**. Then press repeatedly until the radio menu is shown.

[1] **AST** - Automatic tuning.

[2] **SET***¹ - Setting a station.

[3] **TP** *² - Traffic information TP mode.

[4] **TA** *² - Traffic information TA mode.

[5] **BAS** *¹ - Adjusting sound quality.

[6] **TRE** *¹ - Adjusting sound quality.

[7] **FAD** *¹ - Front/rear volume balance.

[8] **BAL** *¹ - Left/right volume balance.

*¹ Available only when the vehicle is not moving.

*² FM mode only

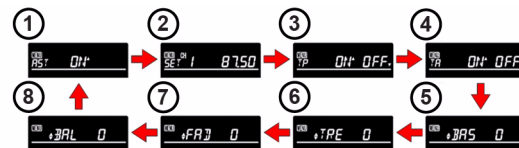

Automatic Tuning

Press  several times until FM or AM mode is displayed.

To scan for receivable stations, press and hold ?" ^ " or " V " on  until a beep is heard.

Manual Tuning

Press  several times until FM or AM mode is displayed.

Press ?" ^ " or " V " on  to select a preset station.

Storing Stations

Press and hold  until a beep is heard. **MENU** appears in the top left-hand corner of the **DISPLAY**. Then press repeatedly until the "SET" is shown.

Search for desired stations by pressing ?" ^ " or " V " on .

Select one of the preset stations (CH1-6) by pressing " + " or " - " on .

Press and hold " + " or " - " on  for the station the current preset is to be set to, until a beep is heard.

Autostoring Stations

Press and hold  until a beep is heard. **MENU** appears in the top left-hand corner of the **DISPLAY**. Then press repeatedly until the "AST" is shown.

Press " + " on  to select ON.

Up to six stations are set in order of reception quality. When the settings are finished, two beeps will be heard. In FM1 or FM2 mode, the stations automatically set by the audio system will be set in the FM3 presets.

Radio Data System

Radio Data System (RDS) is a system that links together specific network transmitters. It is used, for example, to tune the correct frequency of a station irrespective of the transmitter or the current audio source (e.g. CD). The system can also be used for receiving traffic information (TP and TA).

Messages with a programme code (such as news from RDS stations) will interrupt other audio sources at the volume set for this. As soon as the news broadcast is finished, the audio system returns to the previous audio source and resumes the previous volume setting.

 *Some radio stations do not use RDS or only use a limited range of its features.*

TP - ON or OFF

Press and hold  until a beep is heard. **MENU** appears in the top left-hand corner of the **DISPLAY**. Then press repeatedly until the "TP" or "TA" is shown.

Press " + " on  to select ON.

Press "MUTE" on  to select OFF.

Alarm

Alarms are transmitted automatically. The function cannot be set to OFF. "ALARM" is shown on the **DISPLAY** when an alarm message is broadcast. The function is used to warn motorists of serious accidents or disasters.

Traffic Information

TP ON: The system automatically switches to traffic information when a broadcast with a traffic information signal is received.

 *The station returns to the previous one when the traffic information ends.*

TA ON: Traffic information can be heard only when a signal is received. The system switches to the mute mode when a signal is not received. In the CD or MP3/ WMA mode, the system automatically switches to traffic information when a signal is received.

 *The audio system returns to the mute, CD or MP3/WMA mode when the traffic information ends.*

The traffic information mode can be selected as follows.

- FM modes: TP? and TA
- CD and AUX modes: TA

Enhanced Other Networks

With Enhanced Other Networks (EON) ON, traffic announcements and news broadcasts interrupt radio programmes.

If the RDS station (with EON data) being listened to is not broadcasting a traffic information programme and the audio system is in the TA (Traffic Announcement) mode, the radio will be switched automatically to a station broadcasting a traffic information programme in the EON AF list when traffic information begins.

CD Player

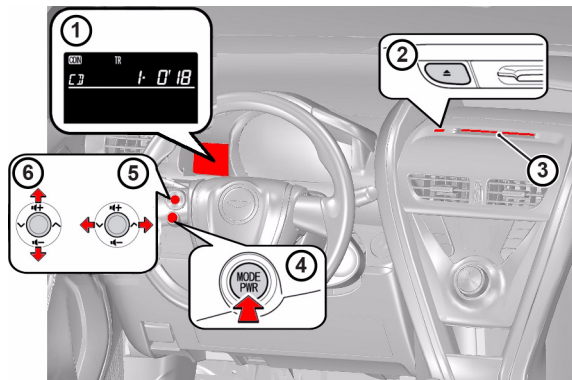

[1] **DISPLAY** - Shows CD information.

[2] **EJECT** - Eject CD.

[3] **CD SLOT** - Opening for CD.

[4] **MODE/PWR** - Audio mode/power ON and OFF.

[5] **TUNING** - Select track/ fast-forwarding or rewinding.

[6] **VOLUME** - Volume control.

Setting the CD Menu

Press and hold **MODE/PWR** until a beep is heard. **MENU** appears in the top left-hand corner of the **DISPLAY**. Then press repeatedly until the CD menu is shown.

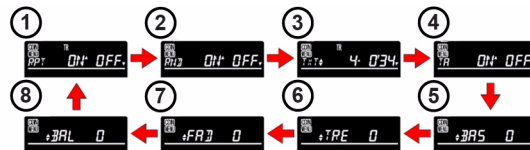

[1] **RPT*** - Repeat a track.

[2] **RND** - Random playback.

[3] **TXT*** - Display text.

[4] **TA*** - Traffic information TA mode.

[5] **BAS*** - Adjusting sound quality.

[6] **TRE*** - Adjusting sound quality.

[7] **FAD*** - Front/rear volume balance.

[8] **BAL*** - Left/right volume balance.

* Available only when the vehicle is not moving.

Loading CDs

Discs that can be used

! *Certification for the CD player*

This product is a class I laser product.

A laser beam leak may result in hazardous radiation exposure.

Do not open the cover of the player or attempt to repair the unit yourself. Refer servicing to qualified personnel.

Laser power: Not hazardous.

Discs with the marks shown below can be used.



Playback may not be possible depending on recording format or disc features, or due to scratches, dirt or deterioration.

CDs with copy-protect features may not be used.

To protect the internal components, playback is automatically stopped when a problem is detected whilst the CD player is being used.

If CDs are left inside the CD player or in the ejected position for extended periods CDs may be damaged and may not play properly. Do not use lens cleaners. Doing so may damage the CD player.

Discs and Adaptors that cannot be used

Do not use the following types of CDs, 8 cm (3 in.) CD adapters or Dual Discs. Doing so may damage the CD player and/or the CD insert/eject function.

- CDs that do not have a diameter of 12 cm (4.7 in.)

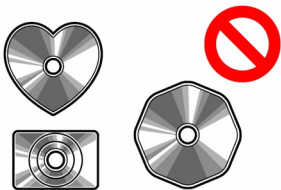

- Low-quality and deformed CDs (critical measurement for CD warp is 0.7 mm - anything more than this may cause problems). The CD player will not be able to hold the CD correctly (because of the warp) and this may cause a jam in the CD player.
- CDs with a transparent or translucent recording area

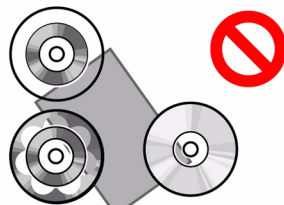
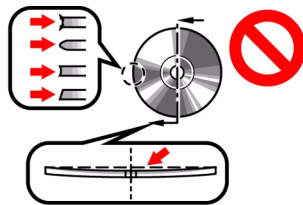

- CDs that have had tape, stickers or CDR labels attached to them, or that have had the label peeled off. The heat from the CD player can cause the label to come loose from the disc and the CD player could be damaged.

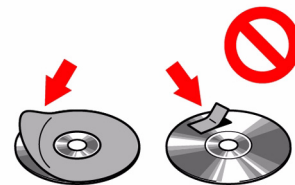

 *If the quality of the CD does not comply with the requirements of standard EN60908 or if it has been recorded using poor equipment, sound quality may be poor or playback interrupted.*

Changing Tracks

Press ?" ^ " or " v " on  until the desired track number is displayed.

Fast Forward and Rewind

Press and hold "▲" or "▼" on .

Repeat Play

Press and hold  until a beep is heard. **MENU** appears in the top left-hand corner of the **DISPLAY**. Then press repeatedly until the "RPT" is shown.

Press "⏮" on  to select ON.

Press "⏭" on  to select OFF.

Random Play

Plays tracks from a CD in random order.

Press and hold  until a beep is heard. **MENU** appears in the top left-hand corner of the **DISPLAY**. Then press repeatedly until the "RND" is shown.

Press "⏮" on  to select ON.

Press "⏭" on  to select OFF.

Disc Text

Some CDs have title information. The information is shown as text on the **DISPLAY**.

Press and hold  until a beep is heard. **MENU** appears in the top left-hand corner of the **DISPLAY**. Then press repeatedly until the "TXT" is shown.

Press "⏮" or "⏭" on  to switch the display.

Each time the switch is pressed, the display changes in the order of Track no./Elapsed time > CD title > Track name.

Up to eight characters can be displayed at a time. Depending on the contents recorded, the characters may not be displayed properly or may not be displayed at all.

Ejecting a CD

Press **EJECT**.

MP3/WMA Player

Setting the MP3/WMA Menu

Press and hold  until a beep is heard. **MENU** appears in the top left-hand corner of the **DISPLAY**. Then press repeatedly until the MP3 menu is shown.

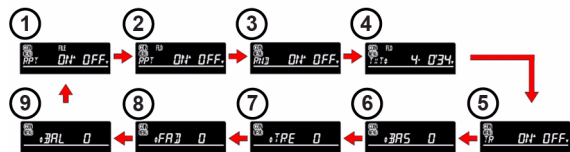

- [1] **RPT FILE*** - Repeat a file.
- [2] **RPT FLD*** - Repeat a folder.
- [3] **RND** - Random playback.
- [4] **TXT*** - Display text.
- [5] **TA*** - Traffic information TA mode.
- [6] **BAS*** - Adjusting sound quality.
- [7] **TRE*** - Adjusting sound quality.

[8] **FAD*** - Front/rear volume balance.

[9] **BAL*** - Left/right volume balance.

* Available only when the vehicle is not moving.

Loading MP3/ WMA discs

Discs that can be used

Discs with the marks shown below can be used.



Playback may not be possible depending on recording format or disc features, or due to scratches, dirt or deterioration.

CDs with copy-protect features may not be used.

To protect the internal components, playback is automatically stopped when a problem is detected whilst the CD player is being used.

If CDs are left inside the CD player or in the ejected position for extended periods CDs may be damaged and may not play properly. Do not use lens cleaners. Doing so may damage the CD player.

MP3 and WMA files

MP3 (MPEG Audio LAYER3) is a standard audio compression format. Files can be compressed to approximately 1/10 of their original size by using MP3 compression.

WMA (Windows Media® Audio) is a Microsoft® audio compression format.

This format compresses audio data to a size smaller than that of the MP3 format.

There is a limit to the MP3 and WMA file standards and to the media/formats recorded by them that can be used.

MP3 file compatibility

Compatible standards

- MP3 (MPEG1 LAYER3, MPEG2 LSF LAYER3)

Compatible sampling frequencies

- MPEG1 LAYER3: 32, 44.1, 48 (kHz)
- MPEG2 LSF LAYER3: 16, 22.05, 24 (kHz)

Compatible bit rates (compatible with VBR)

- MPEG1 LAYER3: 64, 80, 96, 112, 128, 160, 192, 224, 256, 320 (kbps)
- MPEG2 LSF LAYER3: 64, 80, 96, 112, 128, 144, 160 (kbps)

Compatible channel modes

- Stereo
- Joint stereo
- Dual channel
- Monaural

WMA file compatibility**Compatible standards**

- WMA Ver. 7, 8, 9

Compatible sampling frequencies

- 32, 44.1, 48 (kHz)

Compatible bit rates (only compatible with 2-channel playback)

- Ver. 7, 8: CBR 48, 64, 80, 96, 128, 160, 192 (kbps)
- Ver. 9: CBR 48, 64, 80, 96, 128, 160, 192, 256, 320 (kbps)

Compatible media

Media that can be used for MP3 and WMA playback are CD-Rs and CDRWs.

Playback in some instances may not be possible, depending on the status of the CD-R or CD-RW.

Playback may not be possible or the audio may jump if the disc is scratched or marked with fingerprints.

Compatible disc formats

The following disc formats can be used.

- Disc formats:
 - CD-ROM Mode 1 and Mode 2
 - CD-ROM XA Mode 2, Form 1 and Form 2
- File formats:
 - ISO9660 Level 1, Level 2, (Romeo, Juliet)

MP3 and WMA files written in any format other than those listed above may not play correctly, and their file names and folder names may not be displayed correctly.

Items related to standards and limitations are as follows:

- Maximum directory hierarchy: 8 levels
- Maximum length of folder names/file names: 32 characters
- Maximum number of folders: 192 (including the root)
- Maximum number of files per disc: 255

File names

The only files that can be recognized as MP3/WMA and played are those with the extension .mp3 or .wma.

Multi-sessions

As the audio system is compatible with multi-sessions, it is possible to play discs that contain MP3 and WMA files. However, only the first session can be played.

ID3 and WMA tags

ID3 tags can be added to MP3 files, making it possible to record the track title and artist name, etc.

The system is compatible with ID3 Ver. 1.0, 1.1, and Ver. 2.2, 2.3 ID3 tags. (The number of characters is based on ID3 Ver. 1.0 and 1.1.)

WMA tags can be added to WMA files, making it possible to record the track title and artist name in the same way as with ID3 tags.

MP3 and WMA playback

When a disc containing MP3 or WMA files is inserted, all files on the disc are first checked. Once the file check is finished, the first MP3 or WMA file is played. To make the file check finish more quickly, we recommend you do not write in any files other than MP3 or WMA files or create any unnecessary folders.

If the discs contain a mixture of music data and MP3 or WMA format data, only music data can be played.

Extensions

If the file extensions .mp3 and .wma are used for files other than MP3 and WMA files, they will be mistakenly recognised and played as MP3 and WMA files. This may result in large amounts of interference and damage to the speakers.

Playback

- To play MP3 file with steady sound quality, we recommend a fixed bit rate of 128 kbps and a sampling frequency of 44.1 kHz.
- CD-R or CD-RW playback may not be possible in some instances, depending on the characteristics of the disc.
- There is a wide variety of freeware and other encoding software for MP3 and WMA files on the market, and depending on the status of the encoding and the file format, poor sound quality or noise at the start of playback may result. In some cases, playback may not be possible at all.
- When files other than MP3 or WMA files are recorded on a disc, it may take more time to recognize the disc and in some cases, playback may not be possible at all.
- Microsoft[®], Windows[®], and Windows Media[®] are registered trademarks of Microsoft Corporation in the U.S. and other countries.

Loading and ejecting MP3 and WMA discs

Refer to the section entitled "CD Player" for details. (Refer to 'CD Player', page 7.7)

Selecting files

Press ?" ^ " or " V " on  until the desired file is displayed.

Selecting folders

Press and hold ?" ^ " or " V " on  until a beep is heard. Then press ?" ^ " or " V " until the desired folder is displayed.

Repeat Play

To Repeat a File

Press and hold  until a beep is heard. **MENU** appears in the top left-hand corner of the **DISPLAY**. Then press repeatedly until the "RPT" and "FILE" are shown.

Press "+" on  to select ON.

Press "-" on  to select OFF.

To Repeat all of the Files in a Folder

Press and hold  until a beep is heard. **MENU** appears in the top left-hand corner of the **DISPLAY**. Then press repeatedly until the "RPT" and "FLD" are shown.

Press "+" on  to select ON.

Press "-" on  to select OFF.

Random Play

Plays all of the files on a disc in random order.

Press and hold  until a beep is heard. **MENU** appears in the top left-hand corner of the **DISPLAY**. Then press repeatedly until the "RND" is shown.

Press "+" on  to select ON.

Press "-" on  to select OFF.

Disc Text

The information is shown as text on the **DISPLAY**.

Press and hold  until a beep is heard. **MENU** appears in the top left-hand corner of the **DISPLAY**. Then press repeatedly until the "TXT" is shown.

Press "+" or "-" on  to switch the display.

Each time the switch is pressed, the display changes in the order of Folder no./File no./Elapsed time > Folder name > File name > Album title (MP3 only) > Track title > Artist name.

Up to eight characters can be displayed at a time. Depending on the contents recorded, the characters may not be displayed properly or may not be displayed at all.

Auxiliary Functions

Audio Device Connection

The auxiliary input socket can be used to connect a portable audio device and listen to it through the vehicle's speakers.

 *The volume and sound quality can be adjusted using the vehicle's audio controls. All other adjustments must be made on the portable audio device itself.*

Locate the auxiliary socket in the centre console. Connect the audio device to the auxiliary socket using a suitable cable.

If not already ON, set the audio system to ON. Press  several times until AUX mode is shown on the **DISPLAY**.

The media device will now play through audio system.

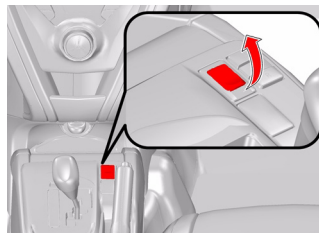

Audio Menus

Radio Menu

- 1) **FM Menu...**
 - 1) News
 - 2) Radio text
 - 3) Advanced Radio Settings...
 - 1) TP...
 - 1) TA...
 - 2) EON...
 - 4) Sound settings...
- 2) **AM Menu...**
 - 1) Sound settings...

CD Changer Menu

- 1) **CD Menu...**
 - 1) Play list
 - 2) Random...
 - 1) Off
 - 3) News
 - 4) Disc text

MP3/WMA Menu

- 1) **MP3/WMA Menu...**
 - 1) Play list
 - 2) Random file...
 - 1) Off
 - 2) Single disc
 - 3) All discs
 - 3) News
 - 4) Disc text

Auxiliary Menu

- 1) **AUX Menu...**
 - 1) AUX input volume...
 - 2) Sound settings...



Hands-Free Phone

Introduction	8.2
Connecting a Phone	8.3
Disconnecting a Phone.....	8.3
Pairing Phones	8.3
Selecting a Phone.....	8.5
Using a Phone.....	8.5
Checking the Phone Status	8.7
Hands-Free Menu	8.7

Introduction

The satellite navigation system also acts as a hands-free system for mobile phones.

A mobile device equipped with hands-free (Bluetooth®) capability can be connected wirelessly to the vehicle's hands-free system. The vehicle's hands-free system then provides remote control of a range of the mobile phone's functions. The mobile phone can always be operated by its own keys regardless of whether or not it is connected.

The system microphone is located in the satellite navigation unit and the speech from an incoming call also comes from the satellite navigation unit.

 *The hands-free phone system does not support SMS (text messages).*



Audio Settings

Call Volume

During a call the call volume can be regulated using the **Volume** button on the main menu of the satellite navigation unit (1).

Muting the Microphone

During a call the **In Call** icon (2) appears. To mute the microphone, press the **In Call** icon, then press **Call Options** and select **Mute Microphone**.



Connecting a Phone

A connection between the hands-free system and a mobile phone is called a 'Paired Link'. When a paired link is set up the hands-free system remembers the mobile phone's ID.

Once the hands-free system and the mobile phone are paired, the hands-free system automatically connects every time the hands-free system and the mobile phone are ON.

A mobile phone can be paired either using the vehicle hands-free system or by using the mobile phone.

 *The process of initiating a hands-free connection with a phone varies per phone manufacturer. For more information refer to the user's guide for your mobile phone.*

Disconnecting a Phone

The mobile phone will **automatically** disconnect when moved out of the hands-free system's range, approximately 10 metres, or Bluetooth® is made unavailable on the mobile phone.

The mobile phone will **manually** disconnect when the hands-free system is set to OFF. The function is also stopped when the "START STOP SWITCH" is set to OFF.

A mobile phone can also be disconnected using the hands-free system:

1. Press **Tools**, then **Settings** and then **Bluetooth** and select **Change**.
2. Select the mobile phone to be disconnected and press **Drop**.

If the mobile phone has been disconnected from the hands-free system during an ongoing call, the call will transfer to the mobile phone.

 *Some mobile phones require that the transfer is confirmed from the phone's keypad.*

Pairing Phones

Initial Pairing

Use this procedure when pairing the first mobile phone to the hands-free system. If the hands-free system is not ON or in use, press and hold the **POWER** button.

To pair the mobile phone and hands-free system using the hands-free system:

1. Press **Tools**, then **Settings** and then **Bluetooth** and select **Add**.
2. Enable the Bluetooth® component on the mobile phone, and enable Find Me / Discoverable / Visible mode. ¹
3. Press **OK**.
4. Select the desired mobile phone from the list and press **OK**.
5. Enter the PIN 1234 into the mobile phone.

¹ This might be in a menu called Settings, Bluetooth, Connections or Hands-free.

To pair the mobile phone and hands-free system using the mobile phone:

1. Press **Tools**, then **Settings** and then **Bluetooth** and select **Enabled**.
2. Enable the Bluetooth® component on the mobile phone. ¹
3. From the mobile phone, initiate a search for Bluetooth® devices.
4. Select the Nuvi 1690 from the list.
5. Enter the PIN 1234 into the mobile phone.

Once the PIN has been accepted the mobile phone is ready for use.

 *If the passkey is not entered after 20 seconds the process will time-out.*

 *Synchronising automatically places all the mobile phone contacts onto the vehicle system.*

Pairing Additional Phones

Pairing Using the Hands-Free System

1. Press **Tools**, then **Settings** and then **Bluetooth** and select **Change**.
2. Enable the Bluetooth® component on the mobile phone, and enable Find Me/Discoverable/Visible mode. ²
3. Press **OK**.
4. Select the desired mobile phone from the list and press **OK**.
5. Enter the PIN 1234 into the mobile phone.

Once the PIN has been accepted the mobile phone is ready for use.

 *If the passkey is not entered after 20 seconds the process will time-out.*

 *Synchronising automatically places all the mobile phone contacts onto the hands-free system.*

Pairing Using the Mobile Phone

 *Disconnect any "in use" phones before pairing additional phones. If a phone is connected to the hands-free system, pairing a new phone will not be possible until the hands-free system has no "in use" Bluetooth® connections.*

1. On the hands-free system, press **Tools**, then **Settings** and then **Bluetooth** and select **Enabled**.
2. Enable the Bluetooth® component on the mobile phone. ³
3. From the mobile phone, initiate a search for Bluetooth® devices.
4. Select the Nuvi 1690 from the list.
5. Enter the PIN 1234 into the mobile phone.

¹. This might be in a menu called Settings, Bluetooth, Connections or Hands-free.

². This might be in a menu called Settings, Bluetooth, Connections or Hands-free.

³. This might be in a menu called Settings, Bluetooth, Connections or Hands-free.

Once the PIN has been accepted the mobile phone is ready for use.

 If the passkey is not entered after 20 seconds the system will time-out.

 Synchronising automatically places all the mobile phone contacts onto the vehicle system.

Removing a Paired Phone

Using the hands-free system

1. Press **Tools**, then **Settings** and then **Bluetooth** and select **Change**.
2. Select the mobile phone to be removed and press **Remove**.

Selecting a Phone

 The phone to be selected must have Bluetooth[®] ON, visible and within 10 metres of the hands-free phone system.

A phone can be selected by using the phone itself or by using the hands-free system:

Using the Mobile Phone

If the hands-free system is not ON or in use, press and hold the **POWER** button. Make sure that Bluetooth[®] is enabled.

Using the mobile phone, follow the manufacturer's instructions to search and connect to a Bluetooth[®] device. The phone will search for discoverable Bluetooth[®] devices in its range. Select Nuvi 1690 from the device list. Select Connect.

Using the hands-free system

If the hands-free system is not ON or in use, press and hold the **POWER** button. Make sure that Bluetooth[®] is enabled.

1. Press **Tools**, then **Settings** and then **Bluetooth** and select **Change**.
2. Select the desired mobile phone from the list and press **OK**.

Using a Phone

Making a Call

Make sure that the hands-free system is ON (the **Phone** symbol shows on the satellite navigation unit **DISPLAY**).

Press **Phone** to access the call menu.

Dialling a Number

Press **Dial** and then dial the number using the keypad and press **Dial**

to call. Press  to erase a number. Press and hold to erase the whole number.

Using Your Phone Book

Press **Phone Book** and then use the UP and DOWN arrows to select a contact from the phone book. Press **Call** to call the contact.

Dialling a Point of Interest

Press **Points of Interest**, select the point of interest to call and then press **Dial**.

Dialling Home

To dial the phone number stored as Home, press **Phone** and then **Call Home**.

To set or edit a home number

1. Press **Where To?** on the main menu.
2. Press **Favourites**.
3. Press **Home**.
4. Select **Press for More**.
5. Select **Edit**, and then **Change Phone Number**.
6. Enter the desired phone number using the keypad.

Viewing Your Call History

Each time a mobile phone connects to the hands-free system, the call history is automatically transferred.

1. Press **Call History**.
2. Select either **Last Received**, **Last Dialed** or **Missed Calls** to view the calls. The last 20 calls are listed in chronological order. The most recent calls are at the top of the list.
3. Select an entry and press **Dial**.

Placing Calls Using Voice Dial

Calls can be placed by speaking the contact's name. The mobile phone may need to be 'trained' to recognise voice commands. Refer to the mobile phone manufacturer's instructions.

1. Press **Voice Dial**.
2. Say the contact name.

Reject a Call

Press **Ignore** whilst the phone is ringing.

Receiving Calls

To answer an incoming call press **Answer**.

During a Call

During a call the **In Call** icon appears. Press the **In Call** icon to display the following options:

- **End Call** - Ends the current phone call
- **Call Options**
 - **Touch Tones** - Displays a keypad page to allow the use of automated systems, such as voice mail
 - **Transfer Audio to Phone** - Switches the call from the hands-free device to the mobile phone. To switch back to the hands-free system at any time, press **Transfer Audio to Device**
 - **Mute Microphone**

Using Call Waiting

When the hands-free system is use and a second call is received the **Incoming Call** window appears. Press **Answer** to answer the call. The initial call will be placed on hold.

Switching Between Calls

- Press **Phone** and then **Switch To**
- Press **End Call** to hang up. This does not disconnect the call on hold

Checking the Phone Status

The battery level and signal strength of the connected mobile phone can be displayed by pressing **Phone** and then **Phone Status**.

Hands-Free Menu

- 1) **Phone Menu...**
 - 1) Last 20 missed calls
 - 2) Last 20 received calls
 - 3) Last 20 dialled calls
- 1) **Phone book...**
 - 1) Search
 - 2) Copy fr. mobile phone
- 2) **Bluetooth...**
 - 1) Change Phone...
 - 2) Remove Phone
 - 3) Connect from mobile phone
- 3) **Phone settings...**
 - 1) Call options...
 - 2) Volume...



ASTON MARTIN



ASTON MARTIN



ASTON MARTIN



ASTON MARTIN



Satellite Navigation

Introduction	9.2
System Controls.....	9.4
Settings Menu	9.6
Finding Destinations.....	9.8
Using the Maps	9.12
Using Traffic Data.....	9.14
Finding Friends with Ciao!™	9.16
Using the nüLink! Services.....	9.18
Managing Files	9.19
Using the Tools	9.20
Frequently Asked Questions	9.24

Introduction

This navigation system has been developed to help guide you to the destination of your choice. The system includes features that lets you to set itineraries, search for certain types of points of interest along your route, store special destinations, etc.

The navigation system can be used without a destination being selected. The map with the position of your vehicle is shown on the **SCREEN** and your vehicle is shown with an icon.

⚠ Warning: Never use the navigation system or any other feature in the vehicle in a way that distracts you from the task of driving safely.

⚠ Warning: Distraction can lead to a serious accident. Set and make changes in the navigation system only with the vehicle parked.

⚠ Warning: Be aware of the current traffic situation.

⚠ Always use good judgment when following navigation system guidance, and do not follow guidance that seems contrary to your own best judgment. Never use the navigation system or any other feature in your vehicle in a way that distracts you from the task of driving safely. Distraction can lead to a serious accident. Set and make changes in your navigation system only with the vehicle parked. Be aware of the current traffic situation. Always comply with relevant traffic regulations.

The navigation system has all maps and features, for the market area, installed in its electronic memory.

Map and feature updates are available from Garmin.

The locations used in this chapter do not necessarily reflect known places and are for the purpose of describing operating procedures only.

Global Positioning System

The satellite navigation system's speed sensor and a gyro calculate the current position and the direction of travel of the vehicle using signals from the Global Positioning System (GPS) satellite system.

Traffic Message Channel Receiver

Standardised code system for traffic information. The Traffic Message Channel (TMC) receiver seeks the relevant frequency. Transmission occurs via FM frequencies¹. The system is currently being expanded.

Removing the Navigation System Unit from the Mount

To remove the navigation system unit from the mount, push the tab on the top of the mount backwards (1) whilst tilting the navigation system unit forwards (2).

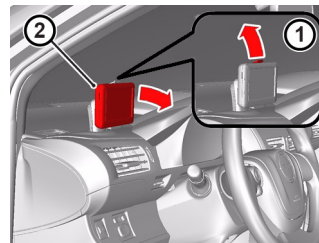

¹. Transmission is not available everywhere.

To remove the mount from the vehicle, push the release button (1), tilt the mount backwards and then lift it upwards (2).

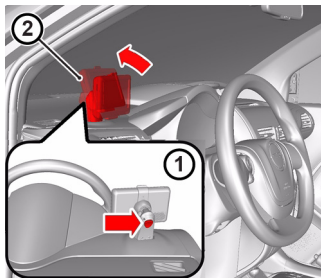

Installing the Navigation System Unit to the Mount

To install the navigation system unit to the mount, tilt the navigation system unit forwards and locate the base of the unit correctly on the mount. Move the unit backwards into the mount until it locks in position.

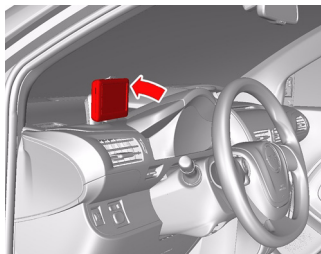

Screen Care

The **SCREEN** must only be cleaned with a soft, lint free, dampened cloth, or a cloth with a mild window cleaning agent.

Software Updates

Connect the navigation system unit to a computer using the mini-USB cable. The AutoPlay menu appears.

Double-click on  **Install myGarmin Agent** to open the myGarmin Agent download page.

Follow the on-screen instructions.

 *If the AutoPlay menu does not open, or a Mac computer is being used, go to www.garmin.com/agent.*

After myGarmin Agent has been installed, there will be a prompt to open myDashboard when the navigation system unit is connected to the computer. myDashboard checks the navigation system for current software and provides additional information about the navigation system.

Map Updates

Factors such as the constant expansion and rebuilding of the road network, new traffic regulations constantly being introduced etc. means that the digital map database is not always up-to-date. Digital maps are continuously updated and the coverage is increased gradually.

Map updates are available from Garmin.



[1] **POWER** - Turns the navigation system ON and OFF.

[2] - Microphone.

[3] **MINI-USB CONNECTOR** - Allows connection to a USB port or charger.

[4] **SCREEN** - Shows maps and provides detailed information on route type, distance, etc.

[5] - Speaker.

[6] - microSD™ card reader.

Using the On-Screen Keyboard

When an on-screen keyboard appears, press a letter or number to enter it.

Press  to add a space.

Press  and  to move the cursor.

Press  to delete a character.

Press and hold  to erase the entire entry.

Press **Mode** to select the keyboard language mode. Press  to enter special characters, such as punctuation marks.





Navigation System ON and OFF

To Set the Navigation System ON

Press and hold the **POWER** button.

The navigation system will then switch ON.

 *The system may need a few minutes to detect your position and movement. The  bars indicate satellite strength. When at least one of the bars is green the system has acquired satellite signals.*

To Set the Navigation System OFF

Press and hold the **POWER** button for approximately three seconds. Alternatively, press and quickly release the **POWER** button, and then select **Power Off**.

 *If the navigation system is ON when the "ENGINE START STOP" switch is turned from ACCESSORY or IGNITION ON to OFF the system will shut down. When the "ENGINE START STOP" switch is turned from OFF to ACCESSORY or IGNITION ON the navigation system will start up automatically.*

Main Menu

The main screen provides access to system functions. To access the main menu from any other screen view press and hold .



[1] **WHERE TO?** - Press to find a destination.

[2] **VIEW MAP** - Press to view the map.

[3] **TOOLS** - Press to use tools such as settings, help, and weather.

[4] **VOLUME** - Press to adjust the system volume.

[5] **PHONE** - Press to make a call when connected to a compatible mobile phone.

Main Menu Toolbar

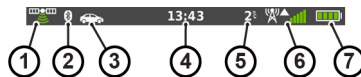

[1] **GPS SIGNAL STATUS** - Press and hold to view satellite information.

[2] **BLUETOOTH® TECHNOLOGY STATUS** - Press to change Bluetooth® settings.

[3] **USAGE MODE INDICATOR** - Press to select a usage mode.

[4] **CURRENT TIME** - Press to change time settings.

[5] **CURRENT TEMPERATURE** - Press and hold to view weather information.

[6] **GARMIN NÜLINK!™ SERVICES SIGNAL STATUS** - Press and hold to view network information.

[7] **BATTERY STATUS** - Indicates power remaining in the battery.

Usage Mode



The navigation system unit can be detached from the vehicle and then used for other modes of travel.

Routing is calculated differently based on the usage mode. For example, in Pedestrian mode with cityXplorer™ maps loaded, the navigation unit calculates a route that uses a combination of public transit options, such as using a bus or subway, and walking. cityXplorer™ maps can be purchased at Garmin.

Changing the Usage Mode

1. Press the Usage mode indicator in the main menu toolbar.
2. Select a mode, and press **OK**.

Guidance Voice

Phone in Use - If guidance voice is ON, guidance messages will be muted if the hands-free phone system is in use.

Settings Menu

To enter the Settings Menu, press **Tools** and then **Settings**.

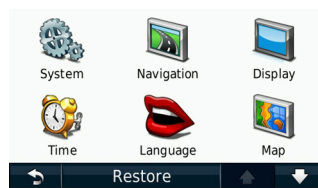

System Settings

GPS Simulator - Select to turn off the GPS mode and simulate navigation, and to conserve battery power.

Usage Mode - Select to optimise routes, and the mode of travel: **Car**, **Pedestrian**, or **Bicycle**.

Units - Select Kilometres or Miles.

Keyboard - Press **QWERTY** to select a layout similar to a computer keyboard, or press **ABCDE** for an alphabetical layout.

About - Displays the navigation unit software version number, the unit ID number, and information on several other software features. This information is required when the system software is updated or additional map data is purchased.

Restore - Restore the original system settings.

Navigation Settings

Route Preference - Select preferences for calculating routes:

- **Faster Time** - Calculate routes that are faster to drive but can be longer in distance.
- **Shorter Distance** - Calculate routes that are shorter in distance but can take more time to drive.
- **Less Fuel** - Calculate routes that could use less fuel than other routes. The route calculation is based on road speeds and vehicle acceleration data for a given route.
- **Off Road** - Calculate point-to-point routes (without roads).

Avoidances - Select the road types to avoid on routes.

Transit Types - Select which mode of public transit to avoid when calculating routes. Transit Types is only available when cityXplorer™ maps are loaded.

Restore - Restore the original navigation settings.

 *When usage modes are changed, the route preference for the usage mode that is changed from will be saved.*

Display Settings

Colour Mode - Select **Day** for a light background, **Night** for a dark background, or **Auto** to automatically switch between the two.

Screen Shot - Turn on Screen Shot mode. Press  to take a screen shot. The picture bitmap file is saved in the screen shots folder on the navigation system unit.

Brightness - Adjust the backlight brightness level. Reducing the backlight brightness increases the battery life.

Restore - Restore the original display settings.

Time Settings

Time Format - select a 12- hour, 24-hour, or UTC (Coordinated Universal Time) format.

Current Time - Manually set the time. Select **Automatic** to set the time based on the current location.

Restore - Restore the original time settings.

Language Settings

Voice Language - Change the language for voice prompts.

Text Language - Change all on-screen text to the selected language. Changing the text language does not change the language of user-entered data or map data, such as street names.

Keyboard - Select the keyboard for the selected language. Press **Mode** on any keyboard to change the keyboard language.

Restore - Restore the original language settings.

Map Settings

Map Detail - adjust the amount of detail shown on the map. Showing more detail can cause the map to redraw slower.

Map View - select a map perspective:

- Track Up - Display the map in two dimensions (2D) with the direction of travel at the top.
- North Up - Display the map in 2D with North at the top.
- 3D - Display the map in three dimensions (3D) in Track Up.

 In **Pedestrian** usage mode, **North Up** is the only map view used.

Vehicle - Press **Change** to change the icon used to display the current position on the map. Select the desired icon, and then press **OK**. Download additional vehicle icons at www.garmin.com.

Trip Log - Show or hide the log of routes. To clear the trip log, press **Tools > My Data > Clear Trip Log**.

Map Data Layout - Change the number of data fields that appear on the Map page.

Info - View the maps and the version of each map loaded onto the navigation system. Select a map to enable (check mark) or disable (no check mark) that map.

Restore - Restore the original map settings.

Security Settings

Garmin Lock™ - Garmin Lock™ is a theft-deterrent system that locks the navigation system unit. Each time the unit is switched on, the correct PIN must be entered or the unit must be driven to the defined security location.

 If you forget your PIN and your security location, the navigation system unit must be sent to Garmin to be unlocked. A valid product registration or proof of purchase must also be sent.

Safe Mode - Turn Safe Mode ON or OFF. When the vehicle is moving, Safe Mode disables all functions that require significant operator attention and could become a distraction whilst driving.

Position Reporting - Turn ON to receive traffic information.

Restore - Restore the original security settings.

 Restoring the security settings will not clear the Garmin Lock PIN or security location.

Bluetooth® Settings

Phone - Press **Add** > **OK** to pair with a mobile phone that has Bluetooth® wireless technology. Press **Change** to connect with a different mobile phone.

- Drop - select the phone you want to disconnect, and press **Yes**
- Remove - select the phone you want to delete from the memory, and press **Yes**

Bluetooth® - turn the Bluetooth® component ON and OFF. The  Bluetooth® icon appears on the Main Menu if the Bluetooth® component is turned ON. To prevent a phone from automatically connecting, press **Disabled**.

Friendly Name - enter a name to identify the navigation system unit on devices with Bluetooth® technology. Press **Done**.

Restore - Restore the original Bluetooth® settings. This does not clear the pairing information.

Proximity Point Settings

 Proximity points (such as custom POIs or a safety camera database) must be loaded to adjust the proximity points settings.

Alerts - Turn the alerts ON or OFF when custom POIs or safety cameras are approached.

Restore - Restore the original proximity points settings.

Restoring All Settings

To restore all of the settings, press **Tools** > **Settings** > **Restore** > **Yes**.

Finding Destinations

The **Where To?** menu provides several different categories to use when searching for addresses, cities, and other locations. The detailed maps contain millions of points of interest, such as restaurants, hotels, and automotive services.

Finding an Address

Press **Address**, and if necessary, change the country.

Search by City

Press **Spell City**.

Enter the name of the city and press **Done**. Select the city from the displayed list.

If known, enter the number of the address and press **Done**.

Enter the street name and press **Done**.

Select the correct street from the displayed list.

Search by Postal Code

Press **Spell Postal Code**.

Enter the post code and press **Done**.

If necessary, select the correct street from the displayed list.

Search All

Press **Search All**.

If known, enter the number of the address and press **Done**.

Enter the street name and press **Done**.

Select the correct city from the displayed list.

 Depending on the version of the maps loaded, the button names can change and some steps could be ordered differently.

Setting a Home Location

Set the Home location for the place returned to most often.

Press **Go Home**

Select an option from the list:

- Enter My Address
- Use My Current Location
- Choose from Recently Found

Going Home

To navigate home after the home location has been set, press **Where To? > Go Home**.

Editing a Home Location

To edit the home location:

Press **Where To?** on the main menu.

Press **Favourites**.

Press **Home**.

Select **Press for More**.

Select **Edit**, and then enter the necessary changes.

Changing a Home Location

To change the home location, press **Tools > My Data > Set Home Location**

Select an option from the list:

- Enter My Address
- Use My Current Location
- Choose from Recently Found

 If the home location is deleted, it can be reset by following the steps in "Setting a Home Location".

Finding Recently Found Places

The navigation system stores the last 50 recent finds in the Recently Found list. The most-recently viewed places appear at the top of the list. Press **Where To? > Recently Found** to view recently found items.

Deleting Recently Found Places

To remove all places from the Recently Found list, press **Clear > Yes**. All items from the list are removed, but this does not delete the actual place from the navigation system.

Using the Go! Page

After a location has been selected to navigate to, the **Go!** page opens.



[1] - Press to view more information for the location.

[2] - Press to zoom in and out.

[3] - If the GPS simulator is ON, press to set the location to the selected location.

[4] - Press to browse the map.

[5] - Press to return to the previous page. Press and hold to return to the Main Menu.

[6] - Press to create a turn-by-turn route to this location.

[7] - Press to save this location to Favourites.

[8] - Press to call this location when connected to a mobile phone.

Finding Points of Interest in Pedestrian Mode

Select Pedestrian usage mode.

Press **Where To? > Points of Interest**.

Select a category.

Select a subcategory.

Select a destination.

Press **Go!**

Finding a Point of Interest by Spelling the Name

Press **Where To? > Points of Interest > Spell Name**.

Use the on-screen keyboard to enter the name of the point of interest. Enter letters contained in the name to narrow the search.

Select a destination.

Press **Go!**

Using Favourites

Places can be saved in Favourites so that they can be quickly found and routes can be created to them. The home location is also stored in Favourites.

Saving the Current Location

From the Map page, press the position marker icon. Press **Save Location** to save the current location.

Saving Places You Find

From the **Go!** page, press **Save**.

Press **OK**. The place is saved in Favourites.

Finding Saved Places

Press **Where To?**

Press **Favourites**.

Select a category.

Select a saved location from the list.

Editing Saved Places

Press **Where To?**

Press **Favourites**.

Select a category and location.

Press **Edit**.

Select an item to edit.

Using Photo Navigation

Pictures that include location information can be loaded onto the navigation system. These pictures can be loaded directly onto the navigation system or via a memory card, and then routes can be created.

Connect the navigation system unit to a computer using the USB link lead.

Download pictures with location information from <http://connect.garmin.com/photos>.

Follow the instructions on the Web site to select and load pictures.

Press **Where To? > Favourites > Photos**. Pictures with location information are listed.

Select a picture.

Sending Found Places

Locations can be sent to the navigation system from various online sources, including <http://connect.garmin.com>.

Find a location on a supported Web site.

Follow instructions on the Web site to send the location to the myGarmin account.

To transfer locations to the navigation system manually, connect the navigation system unit to a computer using the USB cable

Locations sent to the myGarmin account are transferred automatically to Favourites through nüLink! services. Press **Where To? > Favourites** to view the locations.

Finding a Place Using the Map

Use the Browse Map page to view different parts of the map.

Press **Where To? > Browse Map**.

Tips for Browsing the Map

Press anywhere on the map and drag to view different parts of the map.

[1] - Select any object on the map. An arrow appears, pointing at the object, and a box displays information on the location. When the box displays Press for more, several POIs exist at that location. Press to see the list of POIs.

[2] - Press to zoom in and out.

[3] - If the GPS simulator is ON, press **Set Location** to set the location to the selected location.

[4] - Press to return to previous page. Press and hold to return to the Main Menu.

[5] - Press **Go!** to navigate to the location.

[6] - Press **Save** to save the location.



Entering Coordinates

If the geographic coordinates of the destination are known, the latitude and longitude coordinates can be used to navigate to the destination.

Press **Where To?** > **Coordinates**.

Press **Format** to select the correct coordinate format for the type of map.

Select the coordinate to adjust.

Enter the coordinates, and press **Done**.

Press **Next**. The coordinates are displayed on a map.

Adding a Stop

Whilst navigating a route, press  > **Where To?**.

Search for the extra stop.

Press **Go!**.

Select **Add as Via Point** to add this stop before the final destination.

Changing Destinations

Whilst navigating a route, press  > **Where To?**.

Search for the extra stop.

Press **Go!**.

Select **Set as New Destination** to make this the final destination.

Taking a Detour

Whilst navigating a route, press .

Press **Detour**.

If the current route is the only reasonable option, the navigation system may not calculate a detour.

Stopping the Route

Whilst navigating a route, press **Menu**.

Press **Stop**.

Using the Maps

The route is marked with a magenta line. During travel, the navigation system uses voice prompts, arrows on the map, and directions at the top of the map. If the navigation system detects that there has been a departure from the original route, it will recalculate the route.

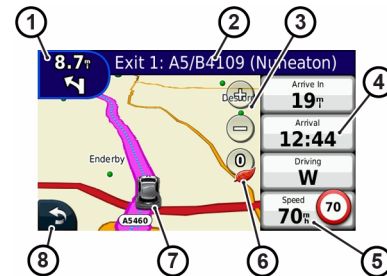

Press and drag the map to view a different area of the map. On major roadways a speed limit icon could appear during the journey.

[1] - Press to view the Next Turn page or the Junction View page, when available.

[2] - Press to view the Turn List.

[3] - Press to zoom in and out.

[4] - Press to view the Trip Computer.

[5] - Press to change the data field.

[6] - Press to view the Driving Challenge score.

[7] - Press to view the Where Am I? page.

[8] - Press to return to the Main menu.

Viewing the Next Turn Page

During navigation, the next turn shows the turn on the map and the distance and time left before the turn is reached.

To view an upcoming turn on the map, press the turn indicator in the upper-left corner of the map, or press any turn on the turn list.



Viewing the Junction Page

When available, the Junction View page displays a view of some upcoming junctions and the correct lane in which to be driving.

To view the Junction View page, press the upper-left corner of the Map page. To access the Junction View page from the Next Turn page, press **Junction View**.

Viewing the Turn List

During navigation, the turn list displays turn-by-turn instructions for the entire route and the distance between turns.

Press the text bar on the top of the map to open the turn list.

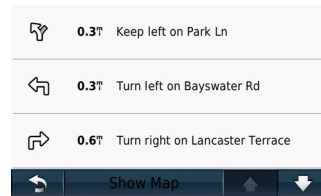

Press a turn on the list to view the next turn for that route.

Press **Show Map** to view the entire route on the Browse Map page.

Viewing the Trip Computer

The trip computer displays the current speed and provides statistics about the trip. To view the trip computer, press the **Speed** field on the map.

If frequent stops are made during the trip, leave the navigation system turned on so that it can accurately measure elapsed time during the trip.



Resetting Trip Computer Information

From the Map View, press the **Speed** field.

Press **Reset** > **Reset Trip Data** to reset the information on the trip computer.

Press **Reset** > **Reset Max** to reset the maximum speed.

Using the Pedestrian Map Page

In Pedestrian usage mode, the route is displayed on a two-dimensional map. The icons indicate the navigation method for that section of the route:

-  • - Walk
-  • - Bus
-  • - Train
-  • - Bicycle
-  • - Car
-  • - Taxi

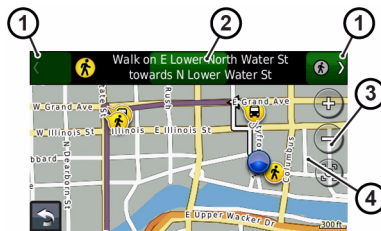

[1] - Press to toggle between legs of the route. The navigation unit zooms in and out on each leg of the route, but it does not automatically move to the next leg.

[2] - Press to view the route itinerary.

[3] - Press to zoom in and out.

[4] - Press to recenter the map on the current location.

Using Traffic Data

 *Aston Martin is not responsible for the accuracy of the traffic information.*

 *nüLink! services are not available in all areas or countries.*

The navigation system can receive traffic information through its nüLink! subscription. It must be receiving a signal from nüLink! services to receive traffic information.

The subscription activates automatically when the navigation system is initially turned. For more information, go to www.garmin.com/nulink or www.garmin.com/nulink/trafficcoverage.

Traffic in the Area

When traffic information is being received, a traffic icon appears in the upper-left corner of the Map page. The traffic icon changes colour to indicate the severity of traffic conditions on the route or on the current road.

Colour	Description	Meaning
Green	Low severity	Traffic is flowing normally
Yellow	Medium severity	Traffic is slightly congested
Red	High severity	Traffic is highly congested or stopped
Grey	No data	Traffic data has not updated

Traffic on the Route

When calculating the route, the navigation system examines the current traffic and automatically optimises the route for the shortest time. If a severe traffic delay occurs on the route whilst travelling, the navigation system automatically recalculates the route. If no better alternative routes exist, it may still show a route through the traffic.

Manually Avoiding Traffic on the Route

On the Map page, press the **Traffic Icon** .

Press **Traffic On Route**.

Press the arrows to view other traffic delays on the route, if necessary.

Select **Avoid** to avoid the traffic delay.

Viewing the Traffic Map

The traffic map shows colour-coded traffic flow and delays on nearby roads.

On the Map page, press the **Traffic Icon**.

Select **Show Traffic Map** to view the traffic incidents on a map.

To return to the normal map from the traffic map, press the **Traffic Icon**, and then select **Show Normal Map**.

Viewing Traffic Delays

On the Map page, press the **Traffic Icon**.

Select **Traffic Search** to view a list of traffic delays.

To view details, select an item in the list. If there is more than one delay, press the arrows to view additional delays.

Disabling Traffic

Press **Tools > Settings > Security**.

Press the button below **Position Reporting** and press **Off**.

Finding Friends with Ciao!™

Ciao! periodically sends your location to our partner networks and downloads the most-recent location of your friends. This application only sends your location when you tell it to, unless automatic updates are enabled. See www.garmin.com/nulink for more information.

A data connection is required for this feature.

 *Ciao! is not available in all areas or countries.*

About Ciao! Networks

Ciao! supports multiple location-based social networks.

When Ciao! is enabled, the network or networks you will be registered with appear in the terms of service.

Joining Ciao!

Before Ciao! can be joined, the navigation system must be registered.

Press **Tools** > **Ciao!**

Select **I Agree**, and press **Continue** to accept the privacy agreement.

On a computer, go to the URL that appears on the navigation system screen, and read the terms of service for the network or networks shown.

Select an option:

- Select **Accept** to accept the terms of service and enable Ciao!
- Select **Decline** to decline the terms of service and leave Ciao! disabled.

Inviting a Friend by Phone Number

Press **Tools** > **Ciao!** > **Invite** > **Invite by phone number**.

Press the button below **Select Country** to select the country where your friend is located.

Select **Change Network** to select a network with which your friend is registered.

Press the button **Enter Phone** and enter a phone number in the proper format for the country selected.

Press **Done**.

Press **Send Invite**.

Inviting a Friend by Email

Press **Tools** > **Ciao!** > **Invite** > **Invite by email address**.

Select **Change Network** to select a network with which your friend is registered.

Press the button **Enter Email** and enter an email address.

Press **Done**.

Press **Send Invite**.

Viewing an Invitation

When a Ciao! invitation is received, a pop-up message appears the next time the friend list is viewed. The pop-up message includes the name of the person who sent the invitation.

Press **Tools** > **Ciao!**

Select **Accept** or **Defer**. If the invitation is accepted, the person who sent the invitation is added to your friend list. If the invitation is deferred, the person will appear in your friend list, but their location cannot be seen.

Press **Yes** to allow the friend to view your location.

Press **Go!** to create a route to the friend, or press **Map** to view the friend on the map.

Accepting or Declining a Pending Invitation

Press **Tools** > **Ciao!**

In the friend list, select a friend whose status is **Pending**.

Select **Accept** or **Decline**.

Viewing Friends

Press **Tools** > **Ciao!** The friend list appears.

Select a friend from the list.

Press **Go!** to create a route to the friend, or press Map to view the friend's location on the map.

Removing a Friend

To stop sharing location information with a friend, they can be removed from Ciao!

Press **Tools** > **Ciao!**

Select a friend from the list.

Press the information balloon on the map.

Press **Remove**.

Press **Yes**.

Entering a Status

Press **Tools** > **Ciao!**

Select your user name in the friend list.

Press the information balloon on the map.

Press **Status**.

Enter a status message with up to 255 characters.

Press **Done**.

Press **Privacy** to read the privacy statement.

Press **Disable** to disable Ciao! and clear Ciao! data from the navigation system.

Changing the Visability

By changing the visibility in the Ciao! settings location updates to Ciao! friends can be switched ON or OFF.

Press **Tools** > **Settings** > **Ciao!**

Press the button under **Visibility**.

Select an option:

- Select **Show** to send location updates to Ciao! friends.
- Select **Hide** to stop sending location updates to Ciao! friends.

Press **OK**.

Disabling Ciao!

Press **Tools** > **Settings** > **Ciao!** > **Disable**.

Press **Yes**.

All the Ciao! information stored on the navigation system is removed. Any position updates are no longer sent.

To enable Ciao!, you must join Ciao! again.

Using the nüLink! Services

The navigation system receives current information on local events, fuel prices, flight times, and more.

 *It may not be possible to receive current data in a remote location.*

 *The nüLink! services are not available in all areas or countries.*

Finding a Destination with Local Search

Local Search enables the most up-to-date location information to be viewed.

Press **Where To? > Local Search**.

Select a category.

Select a subcategory.

Select a destination.

Press **Go!**

 *Local Search is not available in all areas or countries.*

Finding a Place by Spelling the Name

In addition to searching by spelling the name of a location, locations within a specific category can also be searched for, such as hair salons or art galleries.

Press **Where To? > Local Search > Spell**.

Use the on-screen keyboard to enter letters of the name of the destination.

Press **Done**.

Finding a Destination Using Phone Book Listings

Press **Where To? > White Pages**.

Select an option:

- By Name - Search for a listing using first and last names.
- By Phone Number - Search for a listing using a phone number.

Use the on-screen keyboard to enter a name or a phone number, and press **Done**.

Select a listing in the search results, if necessary.

 *The nüLink! services are not available in all areas or countries.*

Finding Fuel Prices

Press **Where To? > Fuel Prices**.

Press **Fuel Type** and select the fuel type for your vehicle. A list of fuel prices per litre at nearby fuel stations appears.

Select a fuel station.

 *Fuel prices are not available in all areas or countries.*

Checking Movie Times

Press **Where To? > Movie Times**.

Press **Select Day** and select an upcoming day.

Select **Find By Movie Title** or **Find By Movie Theatre**.

Select a movie title or a movie theatre.

 *Movie times are not available in all areas or countries.*

Finding Local Events

Press **Where To? > Local Events**.

Select a category.

Press **Select Day** and select an upcoming day.

Select an event.

Press **Save** to save the event to Favourites.

 *Local events are not available in all areas or countries.*

Managing Files

Files, such as JPEG image files, can be stored in the internal memory on the navigation system or on a memory card.

 *The navigation system is not compatible with Windows® 95, 98, Me, Windows NT®, and Mac® OS 10.3 and earlier.*

Supported File Types

- JPEG and JPG image files
- Maps and GPX waypoint files from MapSource®
- GPI custom POI files from Garmin POI Loader

Connecting the Navigation System Unit to a Computer

When the navigation system unit is connected to a computer, an option to install myGarmin Agent™, which monitors the computer USB ports and allows checks for available updates.

Insert a memory card. Press it in until it clicks. ¹

Connect the mini-USB connector to the navigation system unit.

Connect the USB connector to the computer.

¹. Optional.

 *The navigation system unit and memory card appear as removable drives in My Computer in Windows and as mounted volumes on Mac computers.*

 *Some computers with multiple network drives may not display the navigation system unit and memory card drives. See the operating system Help file to learn how to map the drives.*

Transferring Files

Browse the computer for the file to be copied.

Highlight the file, and select **Edit > Copy**.

Open the **Garmin** or memory card drive/volume.

Select **Edit > Paste Item**. The file appears in the list of files in the navigation system memory or on the memory card.

When finished transferring files, click  in the toolbar (system tray),

or drag the volume icon to the Trash  on Mac computers.

Disconnect the navigation system unit from the computer.

Deleting Files

 ***If the purpose of a file is unknown, do not delete it. The navigation system memory contains important system files that should not be deleted.***

Connect the navigation system unit to the computer, and open the navigation system or memory card drive/volume.

Highlight the file to be deleted.

Press **Delete** on the computer keyboard.

Using the Tools

The Tools Menu provides many features that are helpful when travelling.

From the Main Menu, press **Tools**.

Accessing the Settings

For information about the settings, refer to (Refer to 'Settings Menu', page 9.6)

Using the Where Am I? Page

Use the **Where Am I?** page to view current location information, including hospitals, police stations, and fuel.

From the Main Menu, press **Tools > Where Am I?**

Press a button on the right to view the nearest locations in that category.

Press **Save Location** to save the current location.

Accessing Help

Press **Help** to get information about using the navigation system.

Press **Search** to search help topics for a keyword.

Using ecoRoute™

Press **Tools > ecoRoute**.

The ecoRoute feature calculates vehicle fuel economy, your carbon footprint, and the fuel price of navigating to a destination, and also offers tools for improving fuel efficiency.

The data provided by the ecoRoute features are estimates only. The data is not actually read from the vehicle. To receive more-accurate fuel reports for the vehicle and driving habits, calibrate the fuel economy.

The first time ecoRoute is accessed, fuel and mileage information about the vehicle will have to be entered.

Viewing the Fuel Report



If the vehicle profile and the current fuel price has been entered, the navigation system calculates the average fuel economy for the vehicle, your carbon footprint, and the cost of the fuel consumed.

The fuel consumption data is based on estimates for speed and acceleration for an average vehicle.

Press **Tools > ecoRoute > Fuel Economy**.

Calibrating the Fuel Economy

Calibrate the fuel economy to receive more-accurate fuel reports for the vehicle and your driving habits. Calibrate when the fuel tank is filled up.

- Calculate the miles per gallon or litres per 100 kilometres
- Press **Tools > ecoRoute > Fuel Economy > Calibrate**
- Press  and  to enter the result from step 1
- Press **OK**

Adjusting the Fuel Price

Enter fuel price information to calculate the fuel cost of routes and to calculate the fuel reports.

Press **Tools > ecoRoute > Fuel Price**.

Enter the current fuel price, and press **Done**.

Taking the ecoChallenge

The ecoChallenge tool helps to maximise your fuel economy by scoring driving habits. The higher the overall score for an ecoChallenge, the more fuel could be saved.

Press **Tools > ecoRoute > ecoChallenge > Start**.

Understanding the ecoChallenge Score

Press  on the Map page to view details about the current challenge. The leaf colour on the ecoChallenge icon changes depending on the performance in the challenge. The overall score is the average of three scores:

- Acceleration score - Points are gained for gradual acceleration; points are lost for rapid acceleration.
- Deceleration score - Points are gained for gradual braking; points are lost for hard braking.
- Speed score - Points are gained for driving at the best speed for conserving fuel, which is 70–95 km/h for most vehicles.

Stopping the ecoChallenge

From the Map page, press .

Press **Stop** > **Yes**.

Adjusting the Vehicle Profile

Press **Tools** > **ecoRoute** > **Vehicle Profile**.

- Fuel Type - Select a fuel type
- City Fuel Efficiency - Enter the average city fuel efficiency for the vehicle
- Motorway Fuel Efficiency - Enter the average motorway fuel efficiency for the vehicle

For best results, calibrate the fuel economy instead of adjusting the city and motorway fuel efficiency here.

Viewing the Mileage Report

Mileage reports provide the distance, the time, the average fuel economy, and the fuel cost of navigating to a destination.

A mileage report is created for every route that is driven. If a route on the navigation system, a mileage report is created for the distance travelled.

Press **Tools** > **ecoRoute** > **Mileage Report**.

Select a report.

Up to 20 mileage reports can be viewed on the navigation system. Mileage reports can also be accessed in the Reports folder on the navigation system drive/volume.

Viewing Driving Tips

The navigation system provides driving tips to help save fuel.

Press **Tools** > **ecoRoute** > **Tips**.

Resetting ecoRoute Data

Press **Tools** > **ecoRoute**.

Select the category to reset, and press **Reset**.

Viewing myGarmin™ messages

Garmin nüLink! services allows messages to be received from myGarmin.

 nüLink! services are not available in all areas or countries.

Press **Tools** > **myGarmin**.

Select a message to view the whole message.

Viewing Flight Information

Flight status information is a nüLink! service.

 *It may not be possible receive current data in a remote location.*

 *nüLink! services are not available in all areas or countries.*

Press **Tools** > **Flight Status**.

Select a nearby airport.

Select an option to find a flight:

- Check Flight Number - Enter a flight number, and press **Done**
- Search Departures - Select By Destination City, By Airport Code, or All Departures, and enter the appropriate data
- Search Arrivals - Select an airline

Select a flight.

If the flight has multiple connections, press **Next Leg** to check the next flight.

Viewing Weather Information



Weather information is a nüLink! service.

 *It may not be possible receive current data in a remote location.*

 *nüLink! services are not available in all areas or countries.*

Press **Tools** > **Weather**.

Select an option to view weather:

- Press  and  to view weather in other selected areas.
- Select **Forecast** to view a six-day forecast for the displayed location.
- Press anywhere on the screen to bring up a keyboard and search for weather information in another location (not available for the current location weather).

The weather can also be viewed by pressing the current temperature icon in the status bar at the top of the Main menu.



Using the Picture Viewer

Use the picture viewer to view pictures that have been stored in the navigation system or on a memory card.

Press **Tools** > **Picture Viewer**. Use the arrows to scroll through the images.

Use the scroll bar at the bottom of the screen to change how many pictures appear on the screen.

Press a picture to view a larger image of it.

- Press  to view information on the selected picture.
- Press the picture and drag to view different parts.
- Press  to hide the menu bar.

Viewing a Slide Show

Press **Tools** > **Picture Viewer** > . Each picture appears for a few moments.

Press anywhere on the screen to stop the slide show.

Navigating to a Picture

If a picture contains location information, a route can be created to it.

Press **Tools** > **Picture Viewer** > .

Press  > **Go!**

Using the Unit Converter

Press **Tools** > **Unit Converter**.

Press **Conversion**, select a type of measurement, and press **OK**.

Select a unit of measure that to change.

Select a unit of measure, and press **OK**. Repeat if necessary.

Press the box next to the unit of measure to enter a value.

Enter a value, and press **Done**. The unit is converted.

Press **Clear** to perform another conversion.

Using the Currency Converter

Currency conversion rates are automatically updated through the nüLink! service.

 nüLink! services are not available in all areas or countries.

Press **Tools** > **Currency**.

Select the currency to change from and press **OK**.

Select the currency to change to and press **OK**.

Press the box next to a currency to enter a value.

Enter a value, and press **Done**. The currency is converted.

Press **Clear** to perform another conversion.

Using the World Clock

Press **Tools** > **World Clock**.

To change a listed city, select one of the cities.

Enter a city name, and press **Done**.

Select the correct city, if necessary.

Press **World Map** to view a map. Night time hours are shown in the shaded area.

Press  to view the clocks again.

Creating Routes

Routes can be created and saved before commencing a trip.



Press **Where To?** (or **Tools**) > **Routes** > **New**.

Select **Add New Start Point**.

Find a location for the starting point, and press **Select**.

Select **Add New End Point**.

Find a location for the ending point, and press **Select**.

Press  to add another location to the route. Press  to remove a location.

Press **Next** to calculate the route and view it on the map.

Press **Save** to save the route and exit.

Editing Routes

Press **Where To?** (or **Tools**) > **Routes**.

Select the route to edit.

Press **Edit**.

Select an option to edit the route.

Using the Calculator

Press **Tools** > **Calculator** to activate the calculator.

Accessing Saved Data

Use this tool to manage and delete saved data, such as Favourites.

Press **Tools** > **My Data**.

Select an option:

- Set Home Location
- Delete Favourite(s)
- Clear Trip Log
- Remove Ciao™ Friends

Viewing Offers

⚠ Do not attempt to write down the coupon codes whilst driving.

Location-relevant advertisements and coupons are received through the nüLink! services.

When an offer appears on the screen, select the offer to search for the nearest location related to it. If the offer includes a coupon icon, select the coupon icon on the **Go!** page to receive a coupon code. Write down this code and present it on arrival at the location.

To view a list of the offers received, press **Tools** > **Offers**.

Disabling Offers

Press **Tools** > **Settings** > **Security**.

Press the button below Position Reporting and press **Off**.

Frequently Asked Questions

(Q) The position of the vehicle on the map is wrong.

(A) The GPS system shows the position of the vehicle with an accuracy of about 20 m. There is a greater chance of error when driving on roads lying parallel to another road, winding roads, roads on several levels and after driving a long distance without making any distinctive turns. High mountains, buildings, tunnels, viaducts, over or underpasses etc. also have a negative affect on the reception of GPS signals, which means that accuracy in calculating the position of the vehicle may decrease.

(Q) The navigation system does not always calculate the fastest or shortest route.

(A) When calculating a route, distance, width of road, type of road, number of right or left turns, roundabouts etc. are all taken into account in order to produce the best theoretical route. A more efficient selection of route may be possible based on experience and knowledge of the area.

(Q) The position of the vehicle on the map is incorrect after transportation.

(A) If the vehicle is transported, for example by ferry or train, or in such a way as to impede the reception of GPS signals, it can take up to five minutes before the position of the vehicle is correctly calculated.

(A) If power has been cut from the GPS antenna, it can take more than five minutes for the GPS signals to be received correctly and the position of the vehicle to be calculated.

(Q) The map image does not correspond with the real situation.

(A) Factors such as the constant expansion and rebuilding of the road network, new traffic regulations constantly being introduced etc. means that the digital map database is not always complete. The information stored in the maps is constantly being developed and updated. An Aston Martin Dealer can provide further information.

(Q) The system shows the route I am already on when I request <Detour>.

(A) The system cannot find a good alternative to the current route.

(Q) The vehicle symbol on screen jumps forwards or spins.

(A) The navigation system may need a few seconds to sense the position and movement of the vehicle before driving off. Set both the navigation system and the engine to OFF. Start again, but stay stationary for a while before starting to drive.



ASTON MARTIN



ASTON MARTIN



ASTON MARTIN



ASTON MARTIN

Maintenance

Introduction	10.2	Winter Tyres	10.14
Vehicle Jacking.....	10.3	Tyre Sealant Kit	10.14
Servicing Precautions.....	10.3	Vehicle Recovery	10.20
Dangerous Substances.....	10.4	Vehicle Battery	10.23
Emergency Items	10.5	Vehicle Battery Charge.....	10.25
Owner Maintenance	10.5	Fuse Boxes	10.25
Bonnet Release	10.6	Headlamp Bulb.....	10.33
Fluid Levels	10.8	Other External Bulbs	10.35
Windscreen Blade Replacement.....	10.11	Internal Lamps	10.37
Brake Pad 'Bedding-in'.....	10.12	Door Window Reset.....	10.37
Tyres.....	10.12	Vehicle Cleaning	10.38
		Vehicle Storage	10.40

Introduction

Each item in the service schedules must be performed on time as failure to do so may void the new vehicle warranty or other warranties. It is the owner's responsibility to see that the vehicle is maintained correctly and in accordance with the manufacturer's service schedules.

Due to the sophistication of the various systems and the specialised equipment required to maintain this vehicle, owner maintenance should be restricted to the routine procedures described in this owner's guide.

If you think that this vehicle is not functioning correctly, please return it to an Aston Martin Dealer to be checked professionally.

Restraint Systems

Aston Martin recommend that the inflatable (airbags) restraint systems and seat belt components installed to this vehicle are replaced at 10 (ten) year intervals from the date of manufacture on the certification label.

Electronic Fuel Injection

⚠ Warning: If the fuel system is allowed to run dry irreparable damage to the fuel pump may occur.

⚠ Warning: Any modifications or additions to the fuel system not specifically designed by Aston Martin are prohibited. If carried out, they may cause damage to the fuel system which in some circumstances could result in fire. All Service Action Campaigns must be undertaken by an Aston Martin Dealer.

The electronic fuel injection system requires special equipment and test facilities to set up and maintain so that the vehicle gives maximum performance coupled with economy, reliability and safe vehicle emissions. You are, therefore, strongly advised to entrust all service work to an Aston Martin Dealer.

Parts and Lubricants

When undertaking a servicing task only parts, materials, lubricants, etc. that are specifically recommended by Aston Martin should be used. Failure to do so can result in damage to your vehicle and may invalidate your new vehicle warranty or other warranties.

⚠ Your vehicle's warranty may be invalidated if damage is caused by the use of incorrect engine oil. Low quality or obsolete oils do NOT provide the protection required by modern engines. Failure to use engine oil that meets the required specification could cause excessive engine wear, a build up of sludge and deposits, and increased pollution. It could also lead to engine failure.

Vehicle Jacking

⚠ Warning: Make sure that no persons are in the vehicle before jacking commences.

⚠ Warning: Make sure that the park brake is applied and that the vehicle is in Park (Automatic) or first gear (Manual).

⚠ Warning: Make sure that the vehicle is parked on firm and level ground to give a secure base for the jack.

⚠ Warning: Do not raise the vehicle by placing a vehicle jack under the suspension arms.

If this vehicle is to be raised using a vehicle jack make sure that the following jacking points are used.

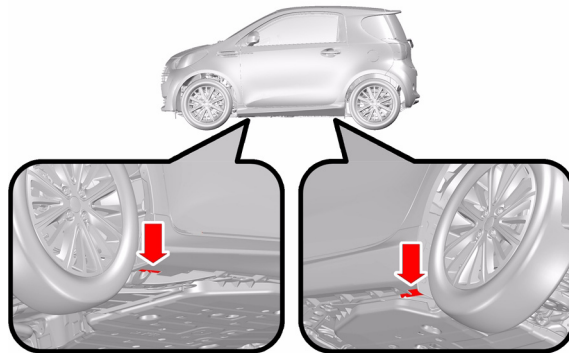

Servicing Precautions

To avoid personal injury, the following safety precautions must be observed when the bonnet is open and the engine is operating or the “ENGINE START STOP” switch is turned to IGNITION ON mode.

⚠ Warning: Protect yourself against dangerous substances.

⚠ Warning: Keep hands, hair, tools, items of clothing and jewellery clear of all drive belts, pulleys and operating mechanisms. The cooling fan may operate even though the engine is not operating.

⚠ Warning: Avoid skin contact with all exhaust system and engine components, engine fluids and escaping steam. They may be hot and will burn you.

⚠ Warning: Do not breathe exhaust fumes. Exhaust fumes contain carbon monoxide. Carbon monoxide is a dangerous gas, which is colourless and odourless and can cause unconsciousness and may be fatal. Never start or leave the engine running in an enclosed, unventilated area.

⚠ Warning: Do not work beneath the vehicle with a vehicle lifting jack as the only support. Place suitable stands under the vehicle.

Dangerous Substances

⚠ Warning: Keep children and pets clear of the vehicle. Do not let anyone inside the vehicle unless specifically working to your instructions.

⚠ Warning: Whenever possible work in the engine compartment with the engine cool, the ignition OFF and the vehicle battery disconnected.

⚠ Warning: Petrol is highly flammable and, in confined spaces, is also explosive and toxic. In the event of spillage, set the engine to OFF, use no naked flame or light. Do not smoke. Do not inhale fumes.

⚠ Warning: Dangerous substances should be kept out of reach of children.

⚠ Warning: Many liquids and other substances used in motor vehicles are poisonous and should under no circumstances be consumed and should, so far as possible, be kept from contact with the skin. These substances include battery electrolyte, antifreeze, oil, brake and clutch fluid, petrol, windscreen washer additives, lubricants, refrigerant and various adhesives.

⚠ Warning: Particular care should be taken to avoid unnecessary contact with used engine oil. Always read carefully the instructions printed on labels or stamped on components and follow them carefully. Such instructions are included for reasons of your health and personal safety. Never disregard them.

Engine Oils

⚠ Warning: Prolonged and repeated contact with used engine oils can cause serious skin disorders, including dermatitis and cancer. Avoid excessive contact, wash thoroughly after contact. Keep out of reach of children. When your oil is changed, be sure that it is done by an experienced person. In addition, observe all laws regarding the disposal of waste oil and toxic fluids.

Protect The Environment

⚠ Warning: It is illegal to pollute drains, water courses, or soil. Use authorised waste disposal facilities, including civic amenity sites and garages providing facilities for receipt of used oil. If in doubt, contact your local authority for advice.

Emergency Items

The following emergency items are located in the boot.

- Tyre Sealant Kit
- First Aid Kit (located underneath the rear luggage box)
- Warning Triangle (located in the luggage compartment)

! *Always follow local regulations when placing a warning triangle.*

Owner Maintenance

In the interests of safety and reliability, it is advisable to carry out the following checks at the intervals suggested (more frequently if your vehicle is heavily used or operating in adverse conditions), and always before starting on a long journey. Refer to the following pages for advice and check procedures.

Before Use Check:

- Operation of lamps, horn, indicators, wipers, washers and warning symbols
- Check there is sufficient fuel for the intended journey, particularly at night and before entering motorways
- Operation of the seat belts
- Operation of the brakes
- Check for fluid deposits underneath the vehicle

Weekly Checks

(daily if covering high mileage or touring)

- Tyres
- Coolant level
- Brake fluid level
- Operate Air Conditioning
- Windscreen washer fluid level
- Check operation of windscreen washers

Engine Oil Level

! *It is important to check the engine oil level regularly. Running the engine with engine oil below the lower mark or above the upper mark can cause serious engine damage.*

Check the engine oil level every fourth fuel tank fill or weekly - whichever is the sooner.

Tool Kit

A vehicle tool kit is located in the boot.

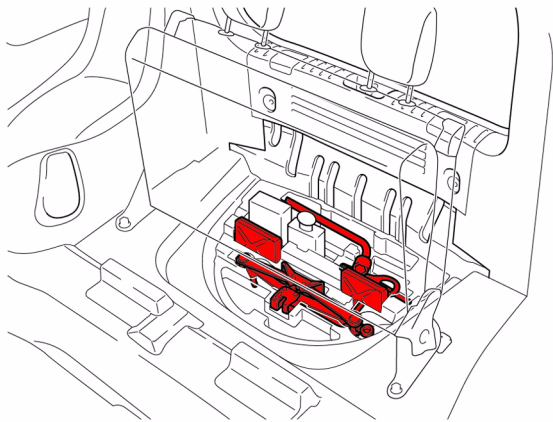

The tool kit consists of:

Towing Eye -

Wheel Brace - For the removal of the front registration plate when installing the front towing eye.

Wheel Chocks - For preventing vehicle movement when lifting the vehicle.

Scissor Jack - For the removal of a road wheel(s) when servicing or maintenance is required.

Bonnet Release

⚠ Warning: Do not pull on the bonnet secondary catch to assist in closing the bonnet. This may displace the bonnet secondary catch. If the catch is displaced it may not work correctly.

⚠ Do not press down hard on the bonnet if it has not closed correctly. This may damage the bonnet.

⚠ Take care not unintentionally to pull on or catch the bonnet release lever.

To open the bonnet pull the lever (1) to release the bonnet latch. The bonnet will rise but stay secured by the bonnet catch.

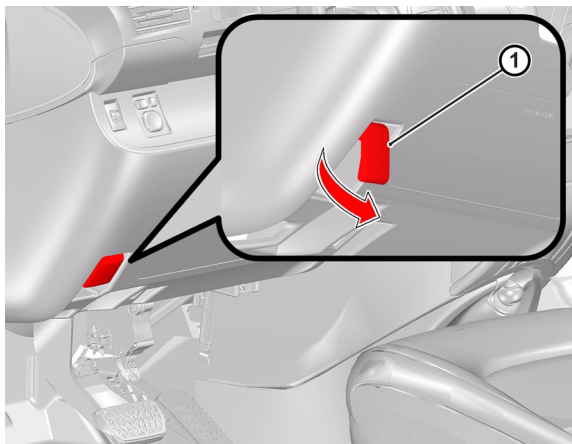

Lift slightly on the bonnet front edge whilst pulling upward on the bonnet secondary catch (2) to release it. Lift the bonnet until fully open.

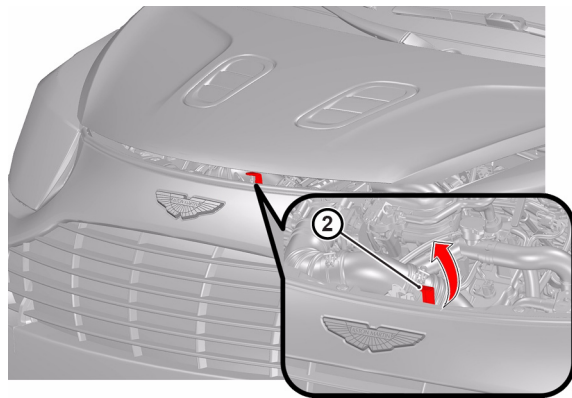

Hold the bonnet open by inserting the supporting rod into the slot.

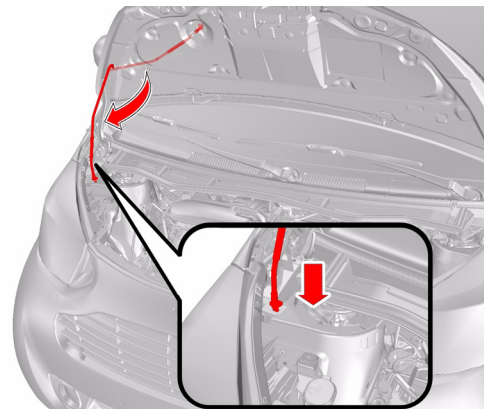

 Before closing the bonnet, remove any tools, cleaning cloths, etc. from the engine compartment. Make sure that no one is obstructing the 'closing' area and that hands, clothing etc. are clear.

To close the bonnet return the support rod to its clip and lower the bonnet until it starts to fall under its own weight. At that point let the bonnet fall to close.

If the bonnet does not shut, open the bonnet again and repeat the closure procedure, this time assist using light hand pressure as the bonnet falls.

Fluid Levels

⚠ Warning: Engine components may be hot and could cause severe burns.

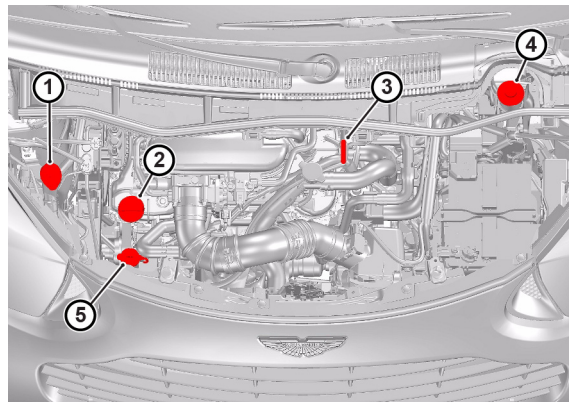

[1] - Washer fluid reservoir.

[2] - Engine oil filler cap.

[3] - Engine oil dipstick.

[4] - Brake fluid reservoir¹.

[5] - Engine coolant filler cap.

¹. Changes sides for left and right hand drive.

Windscreen Wash Fluid Level

Top up as required. In winter, to prevent the windscreen wash fluid freezing, increase the fluid concentration (refer to the manufacturer's recommendations on the windscreen wash fluid container).

To check the level of windscreen wash fluid use the gauge.

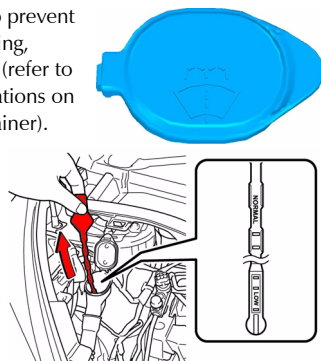

The level can be checked by observing the position of the level on the liquid-covered holes in the gauge. If the level falls below the second hole from the bottom (the LOW position), refill the windscreen wash fluid.

Local or state regulations may restrict the use of Volatile Organic Compounds (VOCs), which are commonly used as antifreeze agents in windscreen washer fluid. A windscreen washer fluid with limited VOC content should be used only if it provides adequate freeze resistance for all regions and climates in which the vehicle will be operated.

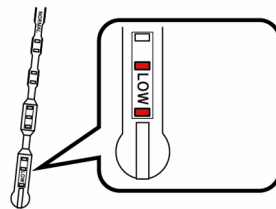

Windscreen Washer Jets

Washer jet housings are located on the rear edge of the bonnet and in the centre of the top edge of the rear windscreen. Each housing contains two washer jets.

Windscreen washer jets are set during manufacture and should not need adjustment. However, if adjustment is required, adjust up or down so that the fluid strikes between a third and half way up the windscreen.

Brake Fluid Level

⚠ Warning: Do not drive the vehicle if the brake fluid level is below the minimum mark.

⚠ Warning: Make sure that the brake fluid does not contact the paintwork during the topping up operation. Serious paintwork damage can result. If a spillage does occur, immediately flush any brake fluid from the paintwork with clean, fresh water and then wipe with a clean damp cloth.

Wipe the reservoir cap clean before removing to prevent ingress of contaminants.



The brake fluid level should read between the Min. and Max. marks.

1. Release and reposition the access cover.
2. Remove the reservoir cap. Top up to the Max. level.
3. Install the reservoir cap securely.

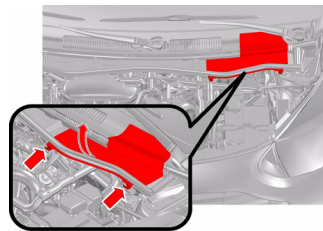

Engine Coolant Level

⚠ Warning: Do not remove the filler cap until the coolant system has cooled. Scalding can be caused by escaping steam or coolant.

📖 Use a cloth or glove to protect hands and protect face and arms adequately.

1. Remove the filler cap to check the coolant level. Top up with the correct antifreeze mix, if required.
2. Make sure that the filler cap is secure after topping up.

If required to remove the filler cap before the engine is cold, **use gloves or a protective cloth** and slowly release the filler cap.



Engine Oil Level

⚠ Warning: Engine oil or components may be hot and could cause severe burns.

! Running the engine with engine oil below the lower mark or above the upper mark can cause serious engine damage.

! This vehicle's warranty may be invalidated if damage is caused by the use of incorrect engine oil. Low quality or obsolete oils do NOT give the protection required by modern, high performance engines.

! Failure to use engine oil that meets the required specification could cause excessive engine wear, a build up of sludge and deposits, and increased pollution. It could also lead to engine failure (Refer to 'Fluids and Capacities', page 11.8).

- The vehicle should be on level ground
- Check the oil level when the engine completely cold
- Check the engine oil level every fourth fuel tank fill or weekly - whichever ever is the sooner

Oil level check:

1. Withdraw and wipe the dipstick clean, using a lint free cloth.
2. Fully insert the dipstick and then withdraw again.



📖 Approximately one and half litres is required to bring the level from L to F.

3. The oil level should read between the L and F. marks.



4. If required remove the filler, top up to the F mark with the recommended engine oil.

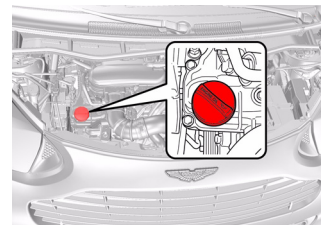

5. Wait for approximately two minutes for the oil to settle, then check the level again. Add oil if required. **Do not overfill.**
6. Replace the filler cap securely, replace the dipstick and press it home.

Windscreen Blade Replacement

To replace a windscreen wiper blade release the retainment clip and disengage the wiper blade from the wiper arm.

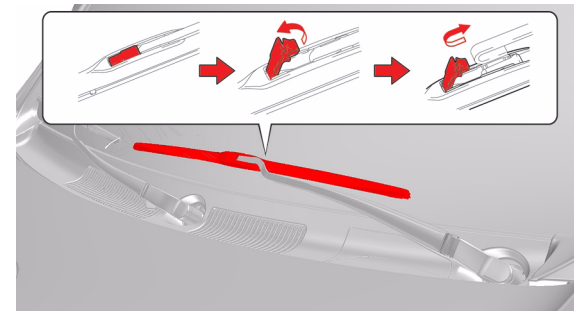

Brake Pad 'Bedding-in'

! Failure to 'bed-in' new brake pads will result in reduced brake performance and possible brake judder or squeal.

After the installation of new brake pads, brake performance will be reduced, as the brake discs and pads need to be 'Bedded-in'. For the first few hundred kilometres of new brake pad use, avoid excessive braking (hard stops from high speed, alpine descents, etc.).

Tyres

Tyres of the correct type, manufacturer and dimensions, with correct cold inflation pressures are an integral part of every vehicle's design. Regular maintenance of tyres contributes not only to safety, but to the designed function of the vehicle.

Road holding, steering and braking are especially vulnerable to incorrectly pressurised, badly installed or worn tyres.

Tyres of the correct size and type, but of different make have widely varying characteristics.

Only install tyres approved by Aston Martin.

Tyre Pressures

Make sure that correct tyre pressures are carefully maintained. Road holding, steering, braking and tyre wear are especially vulnerable to incorrect tyre pressures.

Check tyre pressures regularly and before starting any journey. Re-inflate any tyre with a low pressure at the earliest opportunity.

Pressures increase slightly when the tyres are hot. For an accurate reading, pressures should be checked when the tyres are cold. After adjusting the tyre pressures, make sure that the valve caps are securely replaced to provide an additional air seal and to prevent the ingress of dirt.

Tyre Service

To equalise tyre wear and help extend tyre life, Aston Martin recommends that you rotate your tyres approximately every 10,000 km as shown.

The vehicle is provided with an emergency tyre puncture repair kit, therefore, no spare tyre is provided. When rotating the tyres, contact an Aston Martin Dealer.

 *Aston Martin strongly recommend replacement of any damaged or worn tyre.*

Damage

Tyres should be examined at regular intervals for wear and damage. Inspect the tyre treads and sidewalls for damage, i.e. bulges in the tread or the sidewalls, cracks in the tread groove and separation in the tread or the sidewalls. If damage is observed or suspected have the tyre inspected by a tyre professional.

Stones or other objects which have become lodged in the tyre treads should be carefully removed.

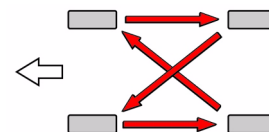

Flat Spots

It is a characteristic of tyres that temporary 'flat spots' may develop if the vehicle is left standing in high or low ambient temperatures for any length of time.

These 'flat spots' will manifest themselves as minor vibrations when the vehicle is first driven from cold. As the tyres warm up to operating temperature, normal tyre shape should be restored and the vibrations cease. If vibrations persist, consult your Aston Martin Dealer.

Age

Tyres degrade over time, even when they are not being used. It is recommended that tyres generally be replaced after five years of normal service. Heat caused by hot climates or frequent high loading conditions can accelerate the aging process.

 *Local regulations on tyre life may apply.*

New Tyres

New tyres should not be installed to the front wheels in combination with worn rear tyres, as rear end stability will be affected. When new tyres are required consult your Aston Martin Dealer for advice if the rear tyres are also worn. Each wheel and tyre unit must be balanced dynamically and measured for Radial Force Variation (RFV)¹ to make sure of efficient steering, optimum tyre wear and maximum ride comfort. It is essential that wheel balancing is carried out when new tyres are installed.

Running-In New Tyres

When new tyres have been installed, speed should be limited, particularly during the first 80 km or so of driving. Fast cornering, hard braking, and harsh acceleration should also be avoided during this period.

Tread Wear Marks

Tread wear marks (A) are incorporated into the construction of all tyres. These marks are integral moulded ribs spaced at regular intervals around the circumference of the tyre and extend across the full width of the tread, in all primary grooves.

When a tyre has worn causing one or more of the marks to be flush with the outer face of the tread the tyre has reached its wear limit. It then becomes illegal in certain countries and must be replaced.



¹. Contact your Aston Martin Dealer for more information.

Winter Tyres

The tyres installed as original equipment are designed with a rubber compound, tread pattern and width specially suited for high speeds in normal road conditions, but they are less suitable during extremes of low temperatures, snow and ice. The use of winter tyres will considerably improve handling during these conditions.

Only use Aston Martin approved winter tyres.

⚠ Warning: Do not drive at speeds in excess of the speed limit or the speed limit specified for the winter tyres being used.

Winter tires must be used in vehicle sets, that is, installed on all four wheels. Do not exceed the tyre speed rating when using winter tyres. Contact your Aston Martin Dealer.

Snow Chains

⚠ Warning: The maximum speed when using snow chains is 50 km/h. Remove the snow chains immediately the roads are clear of snow.

These are available from your Aston Martin Dealer for temporary use when driving in heavy snow conditions. Snow chains should only be installed to the front (driven) wheels.

[1] - 3 mm in diameter

[2] - 10 mm in diameter

[3] - 30 mm in diameter

[4] - 4 mm in diameter

[5] - 14 mm in diameter

[6] - 25 mm in diameter

 Make sure that the installation instructions supplied with the snow chains are kept in a safe place.

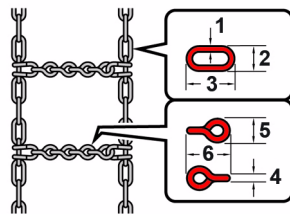

Tyre Sealant Kit

⚠ Warning: Do not use the system to seal a tyre that was damaged whilst driving with insufficient air pressure (e.g. tyre cuts, cracks, bumps or similar damage). Do not use the system to seal tyres with side wall damage. Only punctures in the tread area of tyres may be sealed.

⚠ Warning: Do not stand directly beside the tyre whilst the compressor is pumping. Watch the side wall of the tyre. If there are any cracks, bumps or similar damage set the compressor to OFF. The journey should not be continued. Contact your nearest Aston Martin Dealer.

⚠ Warning: If a tyre pressure of 1.8 bar cannot be reached then the tyre can not be sealed. Do not attempt to re-inflate the tyre. Contact your Aston Martin Dealer.

⚠ Warning: If the pressure in the tyre after driving for 3 km is below 1.3 bar the tyre has not been effectively sealed. The journey should not be continued. Contact your nearest Aston Martin Dealer.

⚠ Warning: After a longer period of rest, the tyre pressure should be rechecked.

! *The tyre sealant kit only provides temporary mobility. Always refer to local laws and regulations on the use and repair of tyres that have been treated with any form of temporary mobility aid. Consult a tyre specialist for advice.*

 *Inform the tyre specialist that the tyre contains sealant.*

Location

The tyre sealant kit is located in the tool kit, which is accessed by removing the rear luggage box (Refer to 'Rear Luggage Box', page 3.22).

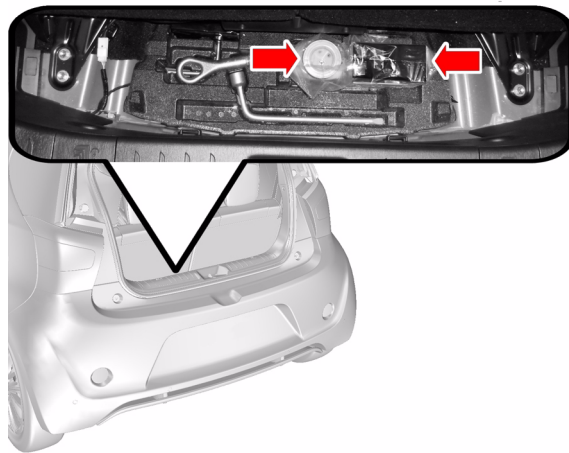

Operation

! *Make sure that the vehicle is parked far enough from traffic so that there is no danger from passing vehicles and so that you do not disrupt the traffic. Warn other vehicles using the warning triangle*

The system should only be used between temperatures of -30°C and 60°C

A maximum speed of 80 km/h may not be exceeded at any time after sealing the tyre with the system

The system provides only a temporary emergency repair for continuing the journey up to 200 km or to the nearest Aston Martin Dealer

If the nearest Aston Martin Dealer is over a 200 km away arrange for collection under the Aston Martin Emergency Service scheme

The system will effectively seal a tyre that was punctured by an object with a diameter of up to 6 mm. It is possible that a tyre, especially with greater damage, will not be sealed. Do not remove objects that punctured the tyre if they are still lodged in the tyre

The sealant bottle needs to be exchanged before it expires. Do not use the system after the expiry date on the sealant bottle or casing has been reached. Contact your nearest Aston Martin Dealer

Do not attempt to inflate other objects without using a system adapter and do not inflate objects with a volume greater than 50 litre (air mattresses, rubber boats, etc.). Do not let the system pump air for more than 10 minutes without stopping it and allowing it to cool down

1. Fold down the rear seat back.
2. Turn and remove the knobs, and remove the luggage box.

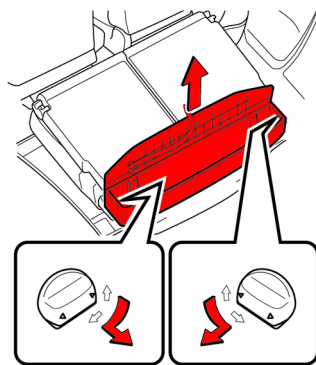

3. Remove the tyre sealant kit.
4. Take out the tyre sealant kit from the plastic bag.¹
5. Remove the valve cap from the valve of the punctured tyre.

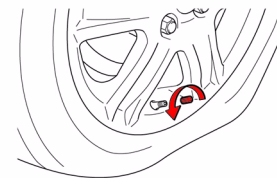
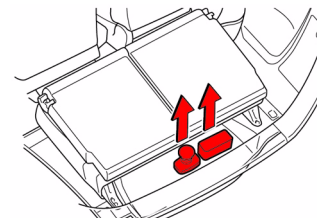

¹ Make sure to place the tyre sealant kit in the plastic bag when storing after use.

6. Remove the air release cap from the hose.

- The air release cap will have to be used again. Therefore keep it in a safe place.

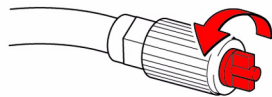

7. Connect the hose to the valve.

- Screw the end of the hose clockwise as far as possible.

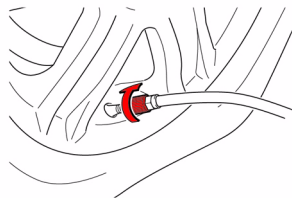

8. Make sure that the compressor switch is off.

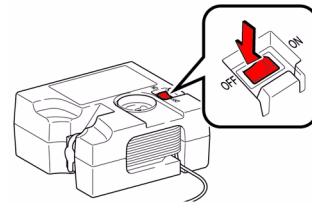

9. Remove the rubber stopper from the compressor.

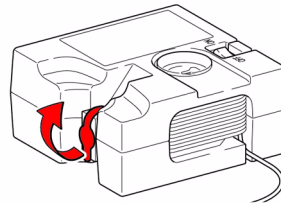

10. Connect the power plug to the power outlet socket.

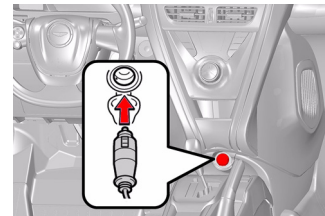

11. Connect the bottle to the compressor.

- Make sure that the bottle is securely connected.

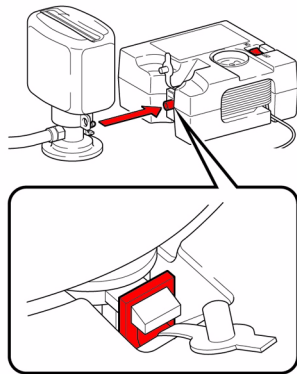

12. Attach the 2 stickers as shown.

- Remove any dirt and moisture from the wheel before attaching the label.

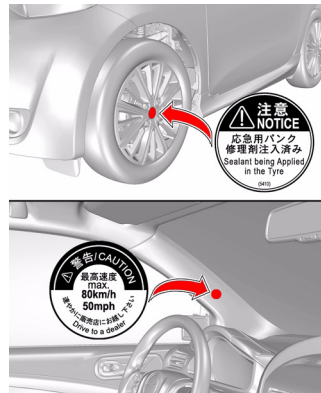

13. Check the specified tyre inflation pressure.

- Tyre inflation pressure is specified on the label on the driver's side pillar as shown.

14. Start the vehicle's engine.

15. To inject the sealant and inflate the tyre, turn the tyre sealant kit switch ON.

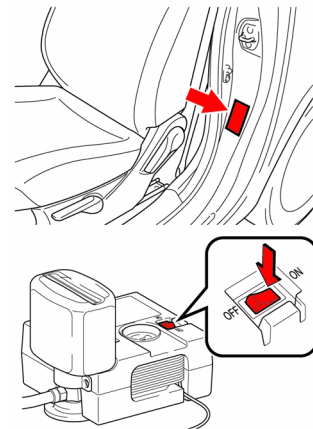

16. Inflate the tyre until the specified air pressure is reached.

[1] - The sealant will be injected and the pressure will spike to the red zone, and then gradually decrease.

[2] - The air pressure gauge will display the actual tyre inflation pressure about 1 minute (15 minutes at low temperature) after the switch is turned ON.

[3] - Inject to specified air pressure.

- Turn the compressor switch OFF and then check the tyre inflation pressure. Being careful not to over inflate, check and repeat the inflation procedure until the specified tyre inflation pressure is reached.

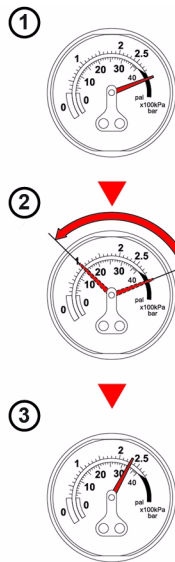

- If the tyre inflation pressure is still lower than the specified point after inflation for 10 minutes (40 minutes at low temperature) with the switch ON, the tyre is too damaged to be repaired. Turn the compressor switch OFF and contact an Aston Martin Dealer.
 - If the tyre inflation pressure exceeds the specified air pressure, let out some air to adjust the tyre inflation pressure.
17. With the compressor switch OFF, disconnect the hose from the valve on the tyre and then pull out the power plug from the power outlet socket.
- Some sealant may leak when the hose is removed.
18. Install the valve cap onto the valve of the emergency repaired tyre.
19. Temporarily store the bottle in the luggage room whilst it is connected to the compressor.
20. To spread the liquid sealant evenly within the tyre, immediately drive for about 5 km below 80 km/h in a safe manner.

21. After driving for about 5 km, stop the vehicle in a safe place on a hard, flat surface and remove the air release cap from the hose before reconnecting the repair kit.

22. Turn the tyre sealant kit switch ON and wait for several seconds, and then turn it OFF. Check the tyre inflation pressure.

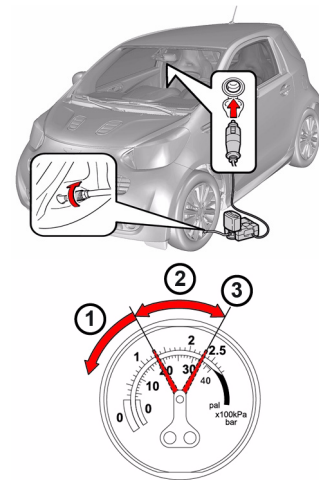

- If the tyre inflation pressure is under 130 kPa (1.3 kgf/cm² or bar, 19 psi): The puncture cannot be repaired. Contact an Aston Martin Dealer.
- If the tyre inflation pressure is 130 kPa (1.3 kgf/cm² or bar, 19 psi) or higher, but less than the specified air pressure: Proceed to step 23.
- If the tyre inflation pressure is the specified air pressure: Proceed to step 24.

23. Turn the compressor switch ON to inflate the tyre until the specified air pressure is reached. Drive for about 5 km and then perform step 21.

24. Attach the air release cap to the end of the hose.

- If the air release cap is not attached, the sealant may leak and the vehicle may get dirty.

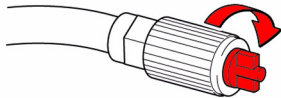

25. Store the bottle in the luggage box whilst it is connected to the compressor.
26. Taking precautions to avoid sudden braking and sharp turns, drive carefully at under 80 km/h to the nearest Aston Martin Dealer for tyre repair or replacement.

Vehicle Recovery

! When moving the vehicle by transporter make sure that the vehicle is not strapped down to the transporter by the suspension control arms.

! Power braking and electric power assisted steering are not available with the engine OFF. Substantially higher brake pedal pressures and steering effort are required.

! If there is a transmission fault, this vehicle must be transported.

Your vehicle should always be recovered on a vehicle transporter₁ and should only be towed for **short distances**, for example, if it is causing an obstruction or if it requires winching onto a transporter.

₁. The recommended method for a recovering vehicle is to have it transported in a purpose built, covered, vehicle transporter.

If moving the vehicle in such a situation:

1. Remove the towing eye from its storage location in the vehicle tool kit. Use the screwdriver to remove the towing eye cover.
 - Protect vehicle paintwork when installing the towing eye.

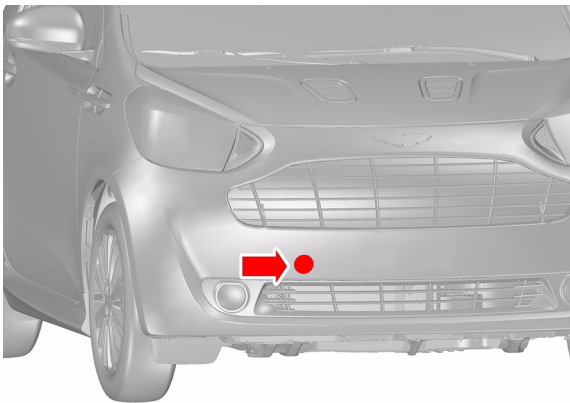

2. Install the towing eye to the exposed female thread.

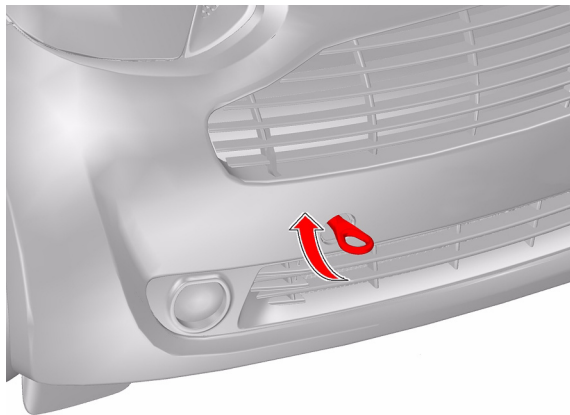

3. If possible put the transmission into Neutral. Operate the "START STOP SWITCH" to IGNITION ON mode to release the steering lock.
4. When being towed use the footbrake very gently as required to prevent excessive slack in the tow rope.

Jump Start From Another Vehicle

⚠ Warning: *The donor vehicle must have a 12 volt battery and a negative (-), black earth terminal to make sure that the correct battery polarity is maintained.*

⚠ *Apart from vehicle recovery, this vehicle must not be driven if the vehicle battery is incapable of starting the engine. In this case the vehicle battery must be replaced.*

⚠ *If the voltage or earth of the donor vehicle is different or not known, do not attempt starting in the way described.*

If this vehicle will not start due to a discharged battery, it may be started, **for vehicle recovery**, by connecting the battery from another vehicle (donor) to this vehicle (recipient).

Jump Start Procedure

⚠ *Remove rings, metal watch bands and any other jewellery.*

⚠ *Set all electrical motors and ancillaries in both vehicles to OFF.*

⚠ *Set all lamps to OFF except those needed to protect vehicles or illuminate the work area.*

1. Position the vehicles so that the connecting cables will reach into the recipient engine bay. Apply the park brake and set the "START STOP SWITCH" to OFF.
2. Access the '+ve' (red) terminal of the battery in the **recipient** engine bay (1).
3. Connect the + ve (red) cable between the '+ve' (red) terminal of the donor battery and the '+ve' (red) terminal of the **recipient** vehicle's battery.

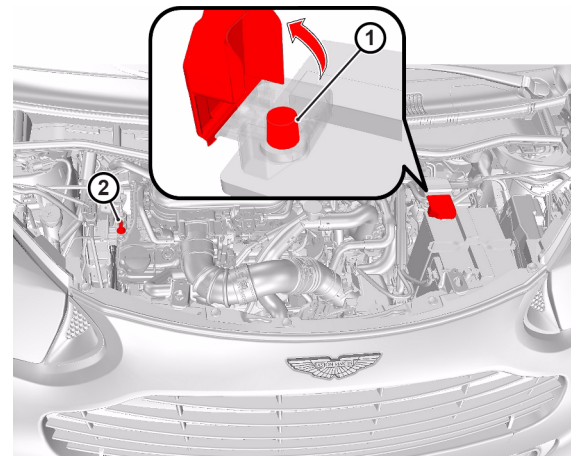



4. Connect the '-ve' (black) cable between the '-ve' (black) terminal of the donor battery and a good earth (-ve) point in the recipient engine bay (i.e. the right side engine mount stud (2)).

Vehicle Battery

5. Start the donor vehicle engine and run at about 1500 – 2000 rpm.
6. Start the engine of the recipient vehicle.
7. Once both vehicles are running remove the jump start cables (first the '-ve' (black) cable from both vehicles and then the '+ve' (red) cable from both vehicles).

Allow the recipient engine to run until the discharged battery is sufficiently recharged (15 to 20 minutes) to start the engine without assistance. Set to OFF and restart the recipient engine. Take the vehicle on a long run to fully charge the battery. Contact your Aston Martin Dealer to have the battery checked or replaced.

 Recharge time will depend on the initial 'state of health' of discharged battery.

 If this vehicle will not start consult your Aston Martin Dealer.

 **Warning: Battery posts, terminals and related accessories contain lead and lead compounds. Wash hands after handling.**

 **Warning: Do not allow flames, sparks or lighted substances to come near the battery. Batteries normally produce explosive gases which can cause personal injury. When working near the battery, always shield your face and protect your eyes. Always have sufficient ventilation.**

 **Warning: When lifting a plastic cased battery, excessive pressure on the end walls could cause acid to flow through the vent caps, resulting in personal injury, damage to the vehicle or battery. Lift the battery with a battery carrier or with your hands on opposite corners.**

 **Warning: Keep batteries out of reach of children.**

 **Warning: Batteries contain sulphuric acid. Avoid contact with skin, eyes or clothing. Shield your eyes when working near the battery to protect against possible splashing of acid solution. In case of acid contact with skin or eyes, flush immediately with water for a minimum of 15 minutes and get prompt medical attention. If acid is swallowed, get medical help immediately.**

 **The engine must never be run with the vehicle battery disconnected.**

 **Apart from vehicle recovery, this vehicle must not be driven if the vehicle battery is incapable of starting the engine. In this case the vehicle battery must be replaced. Contact your Aston Martin Dealer.**

The vehicle battery is located on the left side of the engine bay.

Checking Battery Fluid

Check that the level is between the **UPPER** and **LOWER** marks. If the fluid level is at or below **LOWER**, add distilled water.

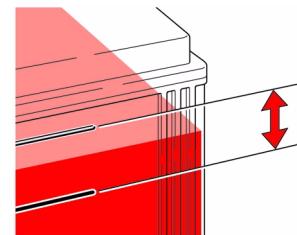

Adding Distilled Water

1. Remove the vent plug.
2. Add distilled water. ¹
3. Put the vent plug back onto the battery and close it securely.

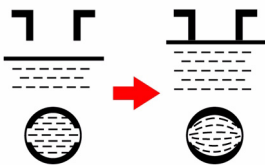

Vehicle Battery Disposal

It is the responsibility of the vehicle owner when disposing of automotive batteries to do it in an environmentally correct manner.

The incorrect disposal of a vehicle (lead-acid) battery can be extremely hazardous to health and the environment. Most batteries contain heavy metals and when disposed of incorrectly, these heavy metals may leak into the ground. This can contribute to soil and water pollution and endanger wildlife.

Follow your local authorised standards for disposal. Call your local authorised recycling centre to find out more about recycling automotive batteries.

Do not dispose of your vehicle battery in the household waste.

Warnings

The following warnings are located on the vehicle battery.



¹ If the **UPPER** mark cannot be seen, check the fluid level by looking directly at the cell.

Vehicle Battery Charge

 *Aston Martin recommend that if this vehicle is to be left unused for ten (10) days or more a battery conditioner (mains power available) should be used.*

Battery charge can be drained excessively in a number of ways:

- If the vehicle is unused for long periods of time
- If the vehicle is used regularly but only for short journeys, e.g. less than 48 km a journey
- If electrical systems are in use without the vehicle engine running

Excessive battery drain would ultimately mean that the battery would not be able to start the engine.

Fuse Boxes

The electrical system is protected by fuses. If any lamps, accessories, or controls don't work, inspect the appropriate circuit protector.

If a fuse has blown, the inside element will be melted. If the same fuse blows again, avoid using that system and consult your Aston Martin Dealer as soon as possible.

Fuse Box Location

[1] ENGINE BAY FUSE BOX - Type A (driver's side).

[2] ENGINE BAY FUSE BOX - Type B (driver's side).

[3] ENGINE BAY FUSE BOX - Type C (passenger's side).

[4] CABIN FUSE BOX - (driver's side front footwell).

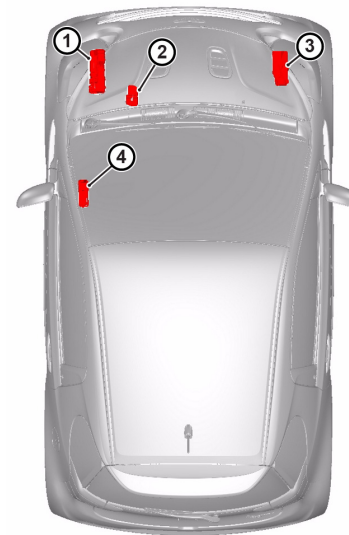

Fuses

Engine Bay Fuses - Type A

To gain access to the fuses, remove the fuse box lid.

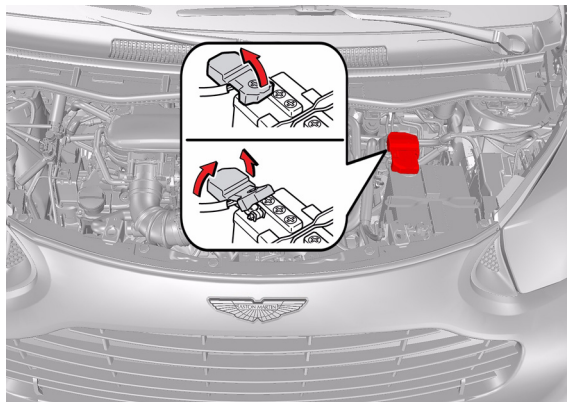

If a fuse is blown (1), contact an Aston Martin Dealer.

Fuse Location

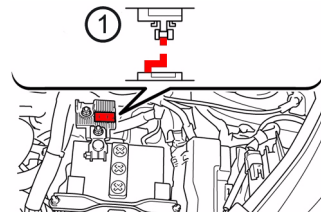
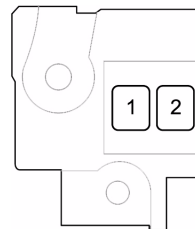

Engine Bay Fuses - Type A

Fuse	Rating	Function
F1	120A	Charging system, RDI, ABS NO.1, HTR-B, ACC, CIG, GAUGE, ECUIG NO.1, HTR-IG, WIPER WASHER, AM1, DOOR NO.1, STOP, DOOR NO.2, OBD, RR FOG, FR FOG, DEF, TAIL NO.2, EPS, PTC NO.1, PTC NO.2, PTC NO.3, DEICER, D/L NO.1, D/L NO.2, PANEL
F2	80A	EFI MAIN, EFI NO.1, HORN, AM2 NO.1, AM2 NO.2, DOME, ECU-B NO.2, TURN&HAZ, H-LP LO, H-LP LH LO, ECU-B NO.1, D/C CUT, ETCS, H-LP HI, IG2, IGN

Engine Bay Fuses - Type B

To gain access to the fuses, push in the tab and lift the fuse box lid off.

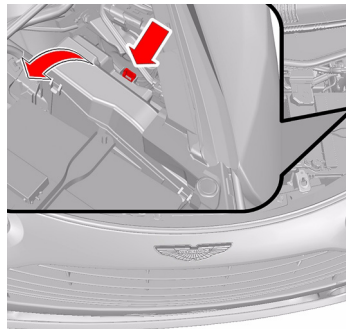

If a fuse is blown (1), replace it with one of an appropriate amperage rating. The amperage rating can be found on the fuse box lid.

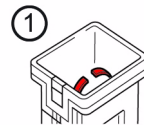

Fuse Location

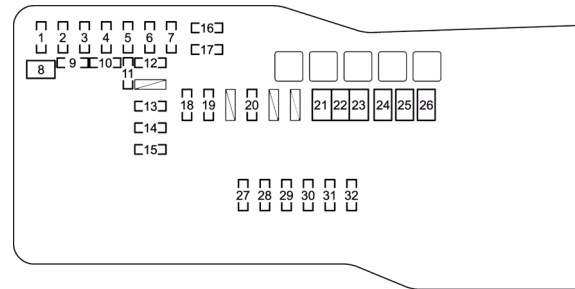

Engine Bay Fuses - Type B

Fuse	Rating	Function
F1	30A	ECU-B NO.1, DOME
F2	7.5A	Smart entry & start system
F3	10A	Turn signal lamps, emergency flashers
F4	10A	Electronic throttle control system
F5	5A	Meter, double locking system, power windows, air conditioning system
F6	7.5A	Power management ECU, Stop & Start system
F7	20A	Headlamp (low beam)
F8	40A	Stop & Start system
F9	30A	Spare fuse
F10	20A	Spare fuse
F11	5A	Spare fuse
F12	30A	Starting system
F13	7.5A	Headlamp (high beam)
F14	20A	Steering lock system

Engine Bay Fuses - Type B

Fuse	Rating	Function
F15		Not used
F16	15A	Interior lamp, audio system
F17	7.5A	Main body ECU, power door lock system, smart entry & start system, Stop & Start system
F18	7.5A	Outside rear view mirror demisters
F19	7.5A	Power management ECU
F20	30A	Rear window demist
F21	50A	Electric power steering
F22	30A	RDI FAN
F23	50A	Anti-lock brake system
F24		Not used
F25	40A	HTR, BLR
F26	30A	Anti-lock brake system
F27	10A	Horn
F28	20A	Multiport fuel injection system/sequential multiport fuel injection system, EFI NO.1, Fuel pump

Engine Bay Fuses - Type B

Fuse	Rating	Function
F29		Not used
F30	15A	Injection, igniter
F31	10A	Smart entry & start system, SRS airbag system, meter
F32	10A	Multiport fuel injection system/ sequential multiport fuel injection system

Engine Bay Fuses - Type C

To gain access to the fuses, release the windscreen washer fluid filler neck from the bracket. Then push in the tab and lift the fuse box lid off

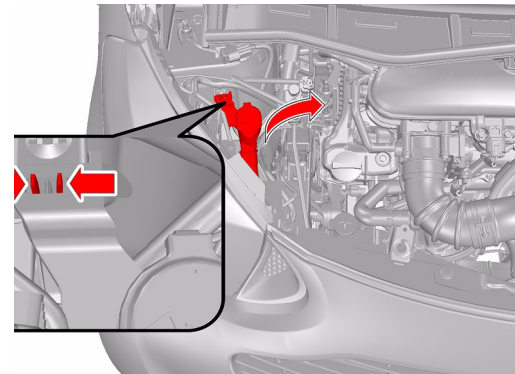

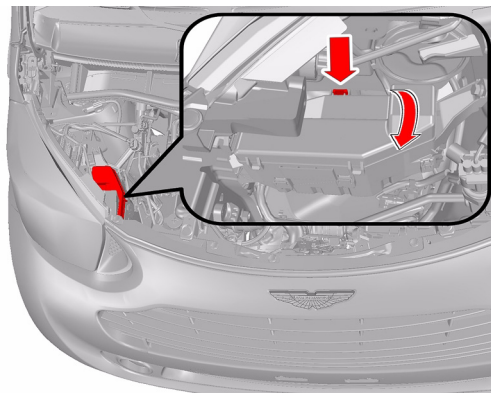

If a fuse is blown (1), replace it with one of an appropriate amperage rating. The amperage rating can be found on the fuse box lid.

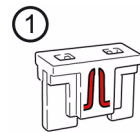

Fuse Location

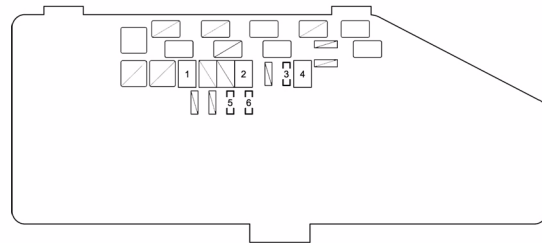

Engine Bay Fuses - Type C

Fuse	Rating	Function
F1	30A	PTC heater
F2	30A	PTC heater
F3	20A	No circuit
F4	30A	PTC heater
F5		Not used
F6		Not used

Cabin Fuse Box

To gain access to the fuses, remove the fuse box lid.

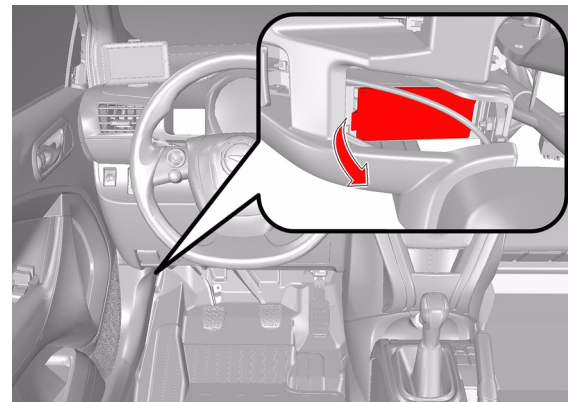

Fuse Location

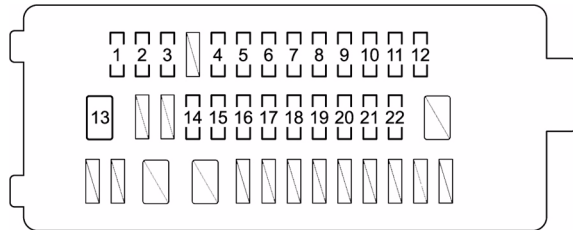

Cabin Fuses

Fuse	Rating	Function
F1	7.5A	Vehicle stability control system, shift lock control system, electric power steering, automatic headlamp, main body ECU, Stop & Start system
F2	10A	Electric cooling fan(s), charging system, emergency flashers, front passenger's seat belt reminder lamp, back-up lamps, multiport fuel injection system/sequential multiport fuel injection system, windshield wiper ECU, auto anti-glare inside rear view mirror
F3	10A	Air conditioning system, wiper deicer, rear window demist
F4	10A	Windscreen washer
F5	10A	Rear window wiper
F6	25A	Windscreen wipers
F7	10A	Windshield washer
F8	7.5A	On-board diagnosis system
F9	7.5A	Rear fog lamp
F10	10A	Manual headlamp levelling dial, front position lamps, tail lamps, license plate lamps
F11	20A	Power windows
F12	15A	Power door lock system, main body ECU
F13	30A	Power windows
F14	15A	Power outlet

Cabin Fuses

Fuse	Rating	Function
F15	5A	Outside rear view mirrors, audio system, shift lock control system, main body ECU, Stop & Start system
F16	5A	Meter, power management ECU
F17	10A	Front position lamps, tail lamps, license plate lamps, rear fog lamp, front fog lamps, manual headlamp leveling dial, multiport fuel injection system/sequential multiport fuel injection system, instrument cluster, windshield wiper ECU
F18	15A	Front fog lamps
F19	7.5A	ACC, starting system
F20	10A	Vehicle stability control system, power management ECU, shift lock control system, stop lamps, multiport fuel injection system/ sequential multiport fuel injection system
F21	10A	Power door lock system
F22	15A	Seat heaters

Headlamp Bulb

 *Headlamp Units: Condensation: The headlamp units will generate condensation under certain conditions. However, this should clear after approximately 10 minutes. If the condensation does not clear, consult your Aston Martin Dealer.*

Left Side Headlamp

1. Push in the tab and lift the fuse box lid off.

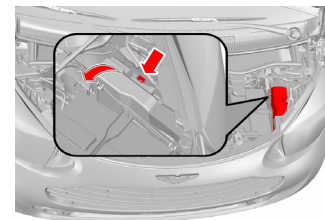

2. Twist the headlamp cover clockwise.

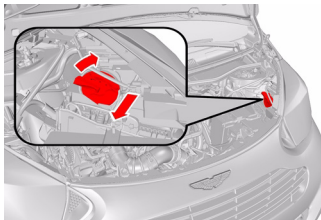

3. Turn the headlamp bulb base counterclockwise.

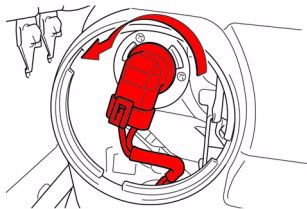

4. Disconnect the electrical connector whilst releasing the clip.

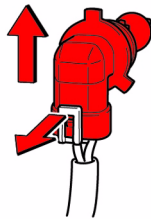

Right Side Headlamp

1. Release the windscreen washer fluid filler neck from the bracket.

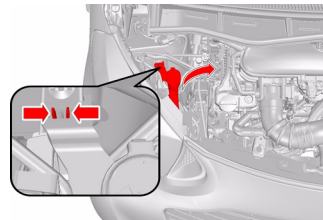

2. Twist the headlamp cover counterclockwise.

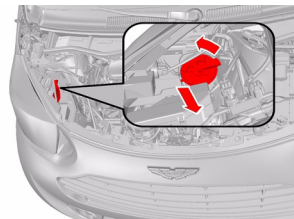

Other External Bulbs

3. Twist the headlamp bulb base counterclockwise.

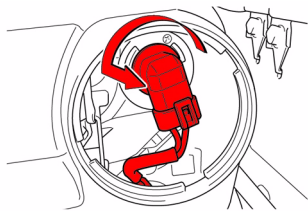

4. Disconnect the electrical connector whilst releasing the clip.

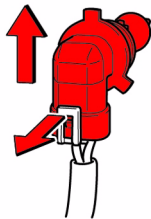

Front Position Lamps

1. Twist the front position bulb base counterclockwise.

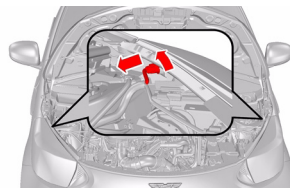

2. Remove the front position bulb.

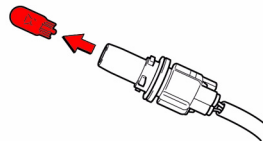

Front Fog Lamps

1. Remove the two bolts that attach the air deflector to the front bumper.

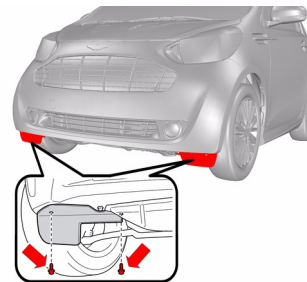

2. Remove the clip and reposition the wheel-arch liner to get access to the fog lamp.

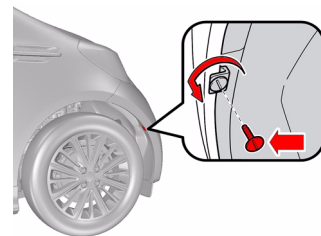

3. Disconnect the electrical connector whilst releasing the clip.

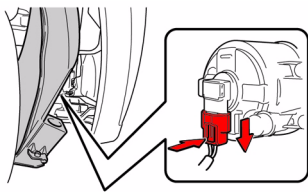

4. Twist the fog lamp bulb base counterclockwise.

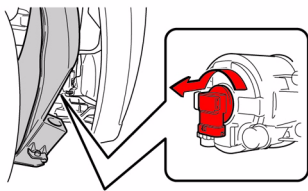

Front Indicators

1. Twist the front indicator bulb base counterclockwise.

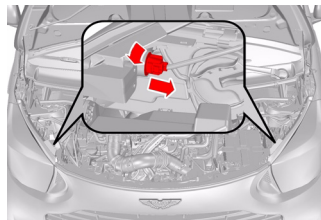

2. Remove the front indicator bulb.

Registration Plate Lamps

1. Take care not to damage the bumper. Use a small, flat blade screwdriver wrapped with a cloth to lever out, from the left side, the lens unit.
2. Twist, counterclockwise, and withdraw the bulb holder.

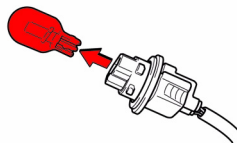

3. Remove the bulb.

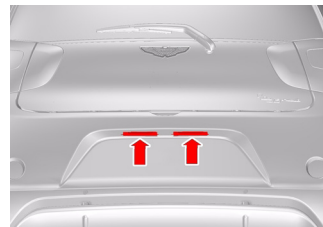

Side Indicators

If a side indicator fails contact your Aston Martin Dealer.

High-Mounted Stop Lamp

The high-mounted stop lamp comprises of LED's and is not repairable. If the high-mounted stop lamp fails contact your Aston Martin Dealer.

 LEDs can last tens of thousands of hours and are resistant to heat, cold, shock and vibration.

Internal Lamps

Rear Lamp Clusters

The rear indicators, stop and tail, reversing lamps and rear fog LEDs are contained in a sealed lamp cluster unit, one either side of the vehicle. The lamp cluster is not repairable, if a rear lamp fails contact your Aston Martin Dealer.

 LEDs can last tens of thousands of hours and are resistant to heat, cold, shock and vibration.

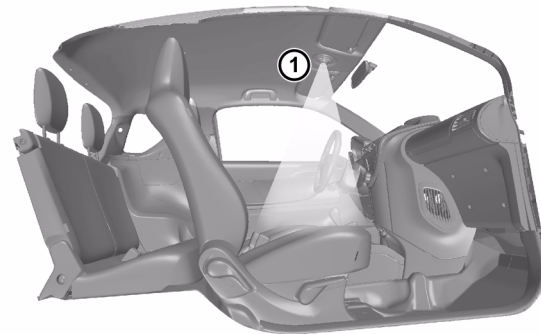

The internal reading lamp (1) comprises of LED's and is not repairable. If the internal reading lamp fails contact your Aston Martin Dealer.

 LEDs can last tens of thousands of hours and are resistant to heat, cold, shock and vibration.

Door Window Reset

If power to the electric windows has been interrupted for any reason, they will fail to operate correctly until reset.

1. Sit in the driver's seat with all doors closed, with the vehicle key on your person, turn the "ENGINE START SWITCH" to IGNITION ON mode.
2. Press firmly and hold the window switch until the window is at the maximum down position. Continue to hold the button for five seconds then release.
3. Pull back and hold the window switch until the window is in the maximum up position. Continue to hold the switch for a further five seconds, then release.
4. The window is now reset. Repeat for the other door windows.

Vehicle Cleaning

Paintwork

Modern water based paints are much safer and more environmentally friendly than solvent based paints. Water based paints are however more susceptible to contamination and marking by corrosive substances. The following list is not exhaustive but does show the most common contaminants which may adversely affect your paintwork:

- Bird Droppings
- Antifreeze
- Tree Sap
- Oils and Greases
- Insect Remains

 *Other groups of contaminants may be added to this list as experience of water based paints and finishes increases.*

Wash such substances from the vehicle using clean warm water with vehicle shampoo, at the earliest opportunity, especially in sunny weather which can accelerate contamination.

Washing

 **Warning: Washing and polishing agents containing silicone should not be applied to glass. This will reduce the efficiency of the windscreen wipers, causing smears which will reduce visibility, particularly during darkness and in the rain.**

 **Commercially operated automatic vehicle washes, jet washes and power operated mops are not recommended. The detergents used can contain certain chemicals which may, over time, be detrimental to some exterior parts of the vehicle. Prolonged usage of automatic vehicle washes and power operated mops will also cause fine scratches in the paint surface.**

For best results, do not wash the vehicle in strong sunlight. Allow the vehicle to cool before washing. Do not use household soaps or detergents. Do not direct water hoses at full force around the door and tailgate seals.

When washing the vehicle, first hose it down first to remove all dust and mud residue.

When dust and mud have been removed wash gently with a soft sponge using cold or warm water with a mild neutral detergent as directed by the detergent manufacturer. Rinse thoroughly with a hose to remove all traces of soapy water. Finally dry with a chamois leather, which should be rinsed regularly in clean water.

Wash and clean the vehicle's front grill in the same way as the paintwork, but make sure that the front grill is dried off completely leaving no water droplets on the grill (wipe the front grill last using a chamois leather): Chrome polish or other abrasive cleaners must not be used.

Aston Martin recommends the use of AUTOGLYM vehicle care products or preparations of similar reputable manufacture for adding to the washing water. Make sure that the manufacture's instructions are followed.

During the winter months, it is advisable to wash the vehicle more frequently, paying particular attention to the underside to combat the detrimental effects of any salt and sand contamination picked up from treated roads.

To delay the onset of corrosion developing on the brake components Aston Martin recommend that after washing this vehicle, the vehicle should be driven a short distance to make sure that all the water and washing product has dried off.

Road Wheels

To avoid possible damage to the alloy road wheels, wheel nuts & wheel centre trims, from a build up of brake dust wash and clean the alloy road wheels frequently, using a mild soapy water solution only. Do not use chemical alloy road wheel cleaners, as they can often have a high acid or alkaline content and could cause discolouration. Always clean one wheel at a time and do not allow the cleaning solution to dry on the wheel. Fully flush off with clean water.

Headlamp Lenses

Only use a mild soapy water solution when washing the headlamp lenses. Do not use cleaning materials which contain solvents. Cleaning materials which contain solvents, i.e. tar remover, petrol, waxes or polishes, may damage the headlamp lens.

Polishing

Approximately twice a year, a good quality polish should be applied to the body work and then buffed, using a soft lint free cloth.

The alloy wheel rims should be treated with a cleaner which is specifically manufactured for this purpose.

Upholstery, Carpets and Seats

⚠ Warning: Fumes from cleaning solvents may be dangerous in confined spaces. Make sure that the vehicle is well ventilated and follow the manufacturer's printed instructions when using these products.

The seats and soft trimmed components of this vehicle are covered in natural leather hide.

In general, this natural leather upholstery requires little attention. The seats should be brushed with a soft brush from time to time and may be cleaned occasionally with a cloth damped in soap and water.

Do not use detergents, quick cleansers or furniture polishes.

Several times a year, a leather conditioner or preservative should be used. Appropriate care materials are obtainable from your Aston Martin Dealer.

Alcantara roof linings and other soft trimmed areas may be brushed with a soft brush. Stains from water based substances such as coffee, tea or soft drinks should be cleaned as soon as possible with mild soap and water.

Consult your Aston Martin Dealer for instructions on the removal of more difficult stains such as oil, grease or ballpoint ink.

Carpets should be cleaned regularly with a vacuum cleaner. Any stains or grease marks should be removed with a good quality solvent suitable for use on carpets.

Care and Maintenance of Seat Belts

! *Do not allow seat belts to be retracted until they are completely dry.*

To make sure that the restraint webbings are in correct working order, regularly check the seat belts. Look for fraying, cuts, burns and similar problems. Make sure that the latches and buckles operate correctly. If a seat belt is not in good condition or is not working correctly, consult your Aston Martin Dealer.

Any seat belt that has been worn during a serious collision should be replaced by an Aston Martin Dealer.

To clean the seat belts, use mild soap and water; do not use bleach, solvents or dyes as they can weaken the material. Allow the seat belts to dry thoroughly before use.

Under Bonnet Cleaning

Under bonnet cleaning using high pressure hoses or steam cleaners should not be carried out. The electronic control module connections and fuse boxes can be damaged by indiscriminate use of high pressure cleaning equipment.

Vehicle Storage

Recommendations

 *These recommendations apply to new and pre-owned vehicles either in dealer or customer ownership.*

If your vehicle is not to be used for periods in excess of three months it should be stored in a dry, well ventilated building.

1. Drive the vehicle for a sufficient distance to warm the oil in the engine and the transaxle; make sure that the internal components of the engine are lubricated.
2. Check the engine coolant level. Top up if necessary with the correct antifreeze and water solution.
3. In order to take the weight off the tyres, raise the vehicle with a jack and place supports under the front and rear suspension.
4. If the vehicle is not raised from the ground, increase the tyre pressures to 3.4 bar. Cover the tyres to exclude any light. Turn the wheels ¼ turn every month to avoid tyre flat spots.
5. If mains power is available, use a battery conditioner to maintain the battery in a fully charged state.

6. Once a month:

- 6.1 Disconnect the battery conditioner (if installed).
- 6.2 Start and operate the engine until it is fully warmed up.
- 6.3 Check there are no fluid leaks.
- 6.4 Set the ignition to OFF.
- 6.5 Connect the battery conditioner.
- 6.6 Check and correct tyre pressures if necessary.

When returning the vehicle to normal service, set the tyre pressures to normal specification before driving on the road.

Extended Storage

For storage periods exceeding six months the following measures are recommended:

 *Do Not Drain Fuel System.*

1. Operate the engine until there is as small a quantity of fuel in the tank as is practical for storage purposes.
2. Add engine oil to the remaining fuel in the tank to make a concentration of 2% (i.e. 20 ml per one ltr of fuel), then operate engine for not less than ten minutes to circulate the mixture thoroughly through all of the fuel system.

3. Inspect rubber connections of coolant system and have them renewed if necessary.
4. Wash the vehicle bodywork thoroughly and repair any paint blisters or patches of corrosion in order to prevent any further deterioration. Apply a suitable polish.
5. Clean the carpets and upholstery thoroughly. Treat all leather upholstery with an application of a leather conditioner or preservative.
6. If the storage building is dry leave vehicle windows slightly open. If there is any tendency towards dampness close vehicle doors and windows and place an anti-moisture compound such as silica desiccant bags in an open metal container inside vehicle.
7. Cover vehicle with a cotton or fabric cover.

Recommissioning after Storage

Provided that the vehicle has been stored in accordance with the recommended procedure, only the following points should need attention before using your vehicle on the road.

⚠ Starting the engine without sufficient lubrication can cause serious engine damage. Make sure that the engine oil pressure is established before the engine starts.

1. Check the tyre pressures, inflate if necessary, lower the vehicle to ground.
2. Drain the engine oil and install a new engine oil filter element. Fill the engine to its maximum level (as shown on the dip stick) with approved oil.
3. Check the coolant level and, if necessary, top up with the correct antifreeze to water solution.
4. Check all fluid levels and top up as necessary.
5. Fill the fuel tank.
6. Start the engine normally and check that the oil pressure and ignition warning symbols go OFF as the engine starts (correct oil pressure and battery charging).

7. Raise the bonnet and check for leaks of fuel, oil and coolant.
8. Carefully test drive your vehicle and check the operation of all functions.

Braking performance can be impaired, initially, due to a fine film of corrosion on the brake disc surface. Drive conservatively and, when safe to do so, frequently apply the brakes until disc surfaces have been cleaned. Full braking performance should then be restored.

If in any doubt about the condition of your vehicle, have it checked by your Aston Martin Dealer.



ASTON MARTIN



ASTON MARTIN



ASTON MARTIN

Specifications

Engine.....	11.2	Wheels.....	11.4
Performance	11.2	Tyres	11.5
Transmission	11.3	Bulbs.....	11.5
Electrics.....	11.3	Vehicle Specification	11.5
Steering.....	11.3	Vehicle Weights	11.6
Suspension.....	11.4	Vehicle Dimensions.....	11.6
Brakes.....	11.4	Vehicle Features.....	11.7
		Fluids and Capacities.....	11.8



Engine

Twin overhead cam 16 valve, inline 4 cylinder

Fuel - Unleaded gasoline only. Recommended 95 RON Unleaded for optimum performance.

Fuel Delivery System - Multi point sequential fuel injection.

Capacity - 1329 cc

Firing Order - 1 - 3 - 4 - 2

Idle Speed -

- Automatic Transmission: 600 to 700 rpm
- Manual Transmission: 550 to 650 rpm

Bore - 72.5 mm

Stroke - 80.5 mm

Spark Plugs - DENSO SC20HR11

Spark Plug Gap - 1.1 mm \pm 0.1 mm

Compression Ratio - 11.5:1

Ignition - 'Coil on Plug' ignition system

Emission Control - Two Oxygen sensors and three-way catalytic convertors. Evaporative loss purge

Lubrication - Wet sump pressurised lubrication

Performance

Maximum Power - 72 kW @ 6000 rpm

Maximum Torque - 123.0 Nm @ 4400 rpm

Maximum Speed - 170 km/h ¹

0-100 km/h -

- Automatic Transmission: 11.6 seconds
- Manual Transmission: 11.8 seconds

¹. Where permitted.

Transmission

Automatic Transmission

Multidrive CVT

Manual Transmission

Six speed transmission

Gear Ratios

1st	3.538:1
2nd	1.913:1
3rd	1.310:1
4th	1.029:1
5th	0.875:1
6th	0.700:1
Reverse	3.333:1

Clutch - Single plate - 200.0 mm diameter

Electrics

Alternator - 100 Amps

Voltage Regulation - 14.4V \pm 0.5V @ 20°C

Battery - Optifit 45 Ah - Vehicles with a manual transmission

Panasonic 36 Ah - Vehicles with an automatic transmission

Steering

Rack and pinion, electric power assisted steering. Column tilt adjustment.

Turns lock to lock - 2.9

Turning Circle - 3.9 m (Kerb to Kerb)

Toe₁ -

Front Total Toe In

1.7 mm (\pm 3.0 mm)

Rear Total Toe In

3.1 mm (\pm 3.0 mm)

Features

- Vehicle Stability Control (VSC)

¹. With the vehicle at its Design Weight. Refer to your Aston Martin Dealer.

Suspension

Front - Coil over monotube dampers and anti-roll bar

Rear - Torsion beam

Brakes

Footbrake

Steel discs all round

	Front	Rear
Diameter	255 mm	259 mm
Callipers	Single piston	Single piston

Park Brake

Lever and cable operated integrated park brake callipers on each rear brake disc.

Brake System Features

- Anti Lock Braking System (ABS)
- Hydraulic Brake Assist (HBA)
- Emergency Brake Assist (EBA)
- Traction Control

Wheels

Aston Martin Aluminium Alloy

Front

5J x 16"

Rear

5J x 16"

Wheel Nut Torque

Tighten each nut in the sequence shown until all four nuts are tightened. Torque tighten all wheel nuts to 103 Nm.

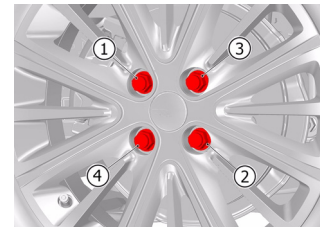

Tyres

Tyre Loading

Tyres installed to this vehicle shall have a maximum load rating of not less than 475 Kg, or a load index of 82 and a speed category of H.

Summer Tyres

Front	Rear
175/60R16	175/60R16

Winter Tyres

Front	Rear
175/60R16	175/60R16

Tyre Air Pressures

Cold Inflation¹

Vehicle Speed	Front	Rear
More than 160 km/h	2.4 bar	2.4 bar
160 km/h or less	2.3 bar	2.3 bar

¹. All Tyres.

Bulbs

	Rating	Type
Headlamps	55W	A
Front indicator lamps	21W	C
Front position lamps	5W	D
Front fog lamps	55W	B
Licence plate lamps	5W	D

Vehicle Specification

Body

Two door Coupe with tailgate. 4 seats

Towing

This vehicle is not engineered to tow any form of caravan, boat or trailer.

No towing devices are approved for installing to this vehicle, other than a front towing eye to aid recovery or loading of this vehicle onto a transporter.

Vehicle Weights

Kerb Weight	988 kg
Gross Vehicle Weight (GVW)	1300 kg
Occupant and Luggage Maximum Load	300 kg

Vehicle Dimensions

Exterior

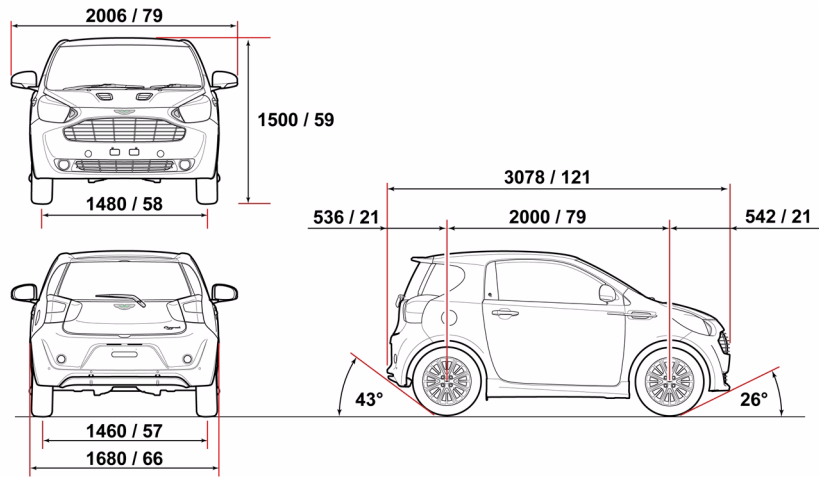

Vehicle Features

Interior

	Front	Rear
Effective Headroom	958 mm	915 mm
Shoulder Room	1360 mm	1260 mm
Hip Room	1370 mm	944 mm
Effective Legroom	795 mm	473 mm

Boot Volume

Boot Configuration	Volume
Rear seat up	32 ltr
Rear seat down	238 ltr

Interior

- Handcrafted full-grain leather seating and trim
- Alcantara headlining
- Machined aluminium details
- Heated front seats
- 50/50 split rear seat
- Automatic climate control
- Security system interacting with the central locking system and PATS immobiliser system
- Driver front airbag
- Driver knee bolster airbag
- Front passenger twin chamber front airbag
- Front passenger seat cushion airbag
- Front and rear passengers side airbags
- Rear curtain airbag
- Audio System with radio, CD/MP3/WMA player and six speaker output with steering wheel mounted controls
- Satellite navigation system
- Keyless entry and start

Exterior

- Door mirrors
 - Heated, electrically adjusted
 - Power fold system
- Electrically operated door windows
- Heated rear window
- Parking assist sensors

Fluids and Capacities

Recommended Fluids

! *To achieve the required high performance of synthetic lubricants, do not mix with mineral oils.*

Engine Oil - The engine in your vehicle has been engineered and fully tested to run with:

- 0W-20, 5W-20, 5W-30 and 10W-30: API grade SL “Energy-Conserving”, SM “Energy-Conserving” or ILSAC multigrade engine oil
or:
- 15W-40 and 20W-50: API grade SL or SM multigrade engine oil

Engine Coolant - 50% water, 50% high-quality ethylene glycol based non-silicate, non-amine, non nitrite, and non-borate coolant with long-life hybrid organic acid technology.

Automatic Transmission Fluid - Aston Martin Genuine CVT Fluid TC

Manual Gearbox Oil - Manual Transmission Oil API GL-4 SAE 75W

Brake and Clutch Fluid - SAE J1703 or FMVSS No.116 DOT3

Air Conditioning Refrigerant - HFC134A

Capacities

Engine Sump (including filter) - 3.5 ltr

Engine Sump (without filter) - 3.3 ltr

Engine Cooling System - Vehicles with a manual transmission - 4.3 ltr

Vehicles with an automatic transmission - 4.5 ltr

Manual Transmission - 2.4 ltr

Automatic Transmission and Cooler - 6.4 ltr

Screen Washer Reservoir - 2.3 ltr

Fuel Tank - 32.0 ltr



ASTON MARTIN



Service

Pre-delivery Inspection	A.2
Servicing	A.4
Service Record	A.6
Anti Corrosion Inspection	A.8
Replacement of Airbag Units	A.10
Replacement of Seat Belt Pre-tensioners	A.10
Field Service Actions	A.11
Service Action Recalls.....	A.12

Pre-delivery Inspection

This free series of checks is carried out on the vehicle by the Selling Dealer before delivery. The checks make sure that you receive a vehicle which matches the high quality standards set by Aston Martin Limited.

Make sure that the entry is stamped and signed as completed. The following checks will be made:

Levels and Leaks

- Engine oil
- Brake fluid
- Engine coolant level
- Engine coolant specific gravity
- Windscreen washer fluid
- Fuel system
- Transaxle leak check
- Battery

Mechanical Functions

- Throttle pedal operation
- Park brake operation
- Steering column adjustment and lock operation
- Seat adjuster rails
- Bonnet release and catch

- Door operation and locks
- Storage compartments
- Rear view mirror
- Boot release and catch
- Seat belt operation

Electrical Checks

- Battery condition
- Gear selection
- Heated rear window
- Windscreen washers
- Windscreen wipers
- Climate control
- Infotainment centre operation
- All speakers
- Reversing, registration plate and brake lamps
- Side and headlamps
- Front fog lamps
- Rear fog lamps
- Hazard warning lamps
- Instrument illumination
- Gauges and warning symbols

- Centre stack controls
- Horns
- Reset clock
- Blower motor
- Seat belt warning system
- Security system and vehicle key
- Interior lamps
- All seat functions
- Door window mechanisms
- Central locking system
- Filler flap lock operation
- Door mirror adjustments
- Interrogate fault codes
- Record battery open-circuit voltage
- Floor console controls

Wheels and Tyres

- Install locking road wheel nuts
- Check road wheel nuts torque
- Tyre pressures
- Tyre orientation

Road Test

- Engine
- Transaxle
- Steering
- Brakes
- Wheel balance
- Gear shift operation
- Noise, vibration or harshness
- Air Conditioner performance
- Instruments operation
- Seat belt and buckle operation
- Steering wheel alignment
- Vehicle stability control, traction control and anti-lock braking system operation

Final Checks

- Drive belt tensioner operation
- Fuel and brake pipe security
- Fuel and fluid leaks
- Security of cooling hoses
- Exhaust catalyst security

Hand-over Preparation

- Check function of locks and vehicle keys
- Clean bodywork and road wheel arch liners
- Clean off all transit labels
- Valet vehicle
- De-grease windscreen
- Install carpets
- Remove interior protection
- Check Owner's Guide
- Check tools
- Install Registration plates
- Tyre sealant kit
- Towing eye
- Field Service Actions and Recall status

Free Pre-delivery Inspection

*0.90 Hours

Service Actions checked:

Open Service Actions completed:

Signature:

Date:

Odometer:

(Dealer Stamp)

* Scheduled operation time.

Servicing

Service Periods

Vehicle servicing is every 16,000 km or 12 months, which ever occurs first.

- 16,000 km or 12 months
- 32,000 km or 24 months
- 48,000 km or 36 months

Service Tables

The following service schedules are recommended for this vehicle. The schedules may be modified if necessary. Please consult your Aston Martin Dealer for details of any service schedule updates.

16,000km 12 months	32,000km 24 months	
Pre-Maintenance		
x	x	Install vehicle protection kit and wing covers
x	x	Check bulletins, field service actions and recall status
Fluids, Filters and Leaks Checks		
x	x	Renew engine oil
x	x	Renew engine oil filter
x	x	Check for engine oil leaks
Every 64,000 km or four years		Renew air cleaner element
x	x	Check transmission for leaks. Top up if required

16,000km 12 months	32,000km 24 months	
Every 64,000 km or four years		Check transmission oil level. Top up if required
-	-	Check differential for leaks, top up if required
160,000 km, then every 97,000 km		Renew engine coolant - check concentration
x	x	Check engine coolant level. Top up if required
x	x	Check cooling and heating systems for leaks
x	x	Check fuel hoses, pipes and unions for leaks, security and condition
-	x	Renew brake fluid
x	x	Check brake hoses, pipes and unions for leaks, security and condition
x	x	Check suspension dampers for leaks
x	x	Top-up windscreen washer reservoir
x	x	Check exhaust system for leaks
x	x	Check Air Conditioning system for leaks
-	x	Renew pollen filter
Mechanical Function Checks		
x	x	Lubricate all door locks and hinges
x	x	Lubricate bonnet catch
x	x	Check security of the bonnet catch
x	x	Check and adjust the accessory drive belt tension. Renew if necessary
x	x	Check park brake security

16,000km 12 months	32,000km 24 months		16,000km 12 months	32,000km 24 months	
x	x	Inspect brake pad wear and condition of discs and callipers. Replace brake pads leads if 60% worn. Check front brake disc shields for fatigue and for clearance to discs.	x	x	Check operation of all warning symbols
			x	x	Check audible warnings including security system
x	-	Check wiper blade inserts. Renew if necessary	x	x	Check operation of the horns
-	x	Renew wiper blades	x	x	Check operation of the windscreen wipers
x	x	Inspect coolant radiator, air conditioning condenser and transmission cooler. Clean if required	x	x	Check windscreen washers and jets
			x	x	Check rear view mirrors for security and function
x	x	Check condition and operation of all seat belts	x	x	Check and operate powerfold mirrors
x	x	Check security of exhaust system mountings and heat shields	x	x	Check and operate electric windows
x	x	Check cooling system hoses security and condition	x	x	Check service interval display. Reset
x	x	Check Air Conditioning hoses security and condition	-	x	Replace vehicle key battery
x	x	Check security and condition of suspension ball joints, gaiters and bushes	Wheels and Tyre Checks		
-	x	Check tightness of drive shaft bolts	x	x	Check for correct tyre size, type and orientation
x	x	Check rear view mirrors for security and function	x	x	Check and report tyre tread depth
-	x	Check condition of underbody protection and wheel arch liners	x	x	Check tyres for uneven, excessive wear or damage
Electrical Function Checks			x	x	Check and adjust tyre pressures
97,000 km		Renew spark plugs	x	x	Check torque of road wheel nuts
x	x	Check and record battery voltage	x	x	Check road wheel rims for inner and outer damage.
x	x	Clean and service the battery connections if required	x	x	Check 'use by' date of tyre repair kit.
-	x	Check headlamp alignment. Adjust if required			
x	x	Check operation of all lamps			

16,000km 12 months	32,000km 24 months	
Anti Corrosion Check		
x	x	Check body panels and underbody for corrosion starting from the inside - out (excluding stone chips).
Gear Change Modes		
x	x	Drive
x	x	Reverse
x	x	Sport
x	x	Braking
Final Checks		
x	x	Degrease windscreen
x	x	Carry out road test - including operation of all gearbox modes
x	x	Check ABS and traction control operation
x	x	Check operation of all seat belts and buckles
x	x	Check that fuel filler bowl rain drain is clear

Service Record

The following service records cover the regular services at 16,000 km or 12 months, whichever ever occurs first, intervals. Make sure that at each service the appropriate entry is stamped and signed as completed.

Vehicle Identification Number (VIN):

Date of Delivery:

* Scheduled operation time.

16,000 km or 12 month	
*0.50 Hours	
Service Actions checked:	
Open Service Actions completed:	
Signature:	
Date:	Odometer:
(Dealer Stamp)	

32,000 km or 24 month
*1.20 Hours

Service Actions checked: _____

Open Service Actions completed: _____

Signature: _____

Date: _____ Odometer: _____
(Dealer Stamp)

64,000 km or 4th year
*1.20 Hours

Service Actions checked: _____

Open Service Actions completed: _____

Signature: _____

Date: _____ Odometer: _____
(Dealer Stamp)

97,000 km or 6th year
*2.20 Hours

Service Actions checked: _____

Open Service Actions completed: _____

Signature: _____

Date: _____ Odometer: _____
(Dealer Stamp)

48,000 km or 3rd year
*0.50 Hours

Service Actions checked: _____

Open Service Actions completed: _____

Signature: _____

Date: _____ Odometer: _____
(Dealer Stamp)

80,000 km or 5th year
*0.50 Hours

Service Actions checked: _____

Open Service Actions completed: _____

Signature: _____

Date: _____ Odometer: _____
(Dealer Stamp)

113,000 km or 7th year
*0.50 Hours

Service Actions checked: _____

Open Service Actions completed: _____

Signature: _____

Date: _____ Odometer: _____
(Dealer Stamp)

Anti Corrosion Inspection

129,000 km or 8th year

*1.20 Hours

Service Actions checked:

Open Service Actions completed:

Signature:

Date:

Odometer:

(Dealer Stamp)

161,000 km or 10th year

*1.30 Hours

Service Actions checked:

Open Service Actions completed:

Signature:

Date:

Odometer:

(Dealer Stamp)

Anti Corrosion Inspection 1st Year

Signature:

Date:

Odometer:

(Dealer Stamp)

145,000 km or 9th year

*0.50 Hours

Service Actions checked:

Open Service Actions completed:

Signature:

Date:

Odometer:

(Dealer Stamp)

Anti Corrosion Inspection 2nd Year

Signature:

Date:

Odometer:

(Dealer Stamp)

Anti Corrosion Inspection 3rd Year

Signature:

Date:

Odometer:

(Dealer Stamp)

Anti Corrosion Inspection 5th Year

Signature:

Date:

Odometer:

(Dealer Stamp)

Anti Corrosion Inspection 7th Year

Signature:

Date:

Odometer:

(Dealer Stamp)

Anti Corrosion Inspection 4th Year

Signature:

Date:

Odometer:

(Dealer Stamp)

Anti Corrosion Inspection 6th Year

Signature:

Date:

Odometer:

(Dealer Stamp)

Anti Corrosion Inspection 8th Year

Signature:

Date:

Odometer:

(Dealer Stamp)

Replacement of Airbag Units

Every 10 years from the date of vehicle registration, all airbag units must be replaced. To make sure this is completed correctly and safely, this work should be carried out by your Aston Martin Dealership.

Airbag Replacement 10th Year

Signature: _____

Date: _____

Odometer: _____

(Dealer Stamp)

Replacement of Seat Belt Pre-tensioners

Every 10 years from the date of vehicle registration, all seat belt pre-tensioners must be replaced. To make sure this is completed correctly and safely, this work should be carried out by your Aston Martin Dealership.

Seat Belt Pre-Tensioners Replacement 10th Year

Signature: _____

Date: _____

Odometer: _____

(Dealer Stamp)

Anti Corrosion Inspection 9th Year

Signature: _____

Date: _____

Odometer: _____

(Dealer Stamp)

Anti Corrosion Inspection 10th Year

Signature: _____

Date: _____

Odometer: _____

(Dealer Stamp)



Aston Martin Assistance

Emergency Service	B.2
Benefits	B.3
Alternative Travel Arrangements	B.4
What To Do In An Emergency	B.6
European Autoroute Restrictions.....	B.7
What is not Covered	B.7
Schedule - Eligible Vehicles	B.11

Emergency Service

As the owner of an Aston Martin vehicle you should enjoy a high standard of trouble free motoring. However, should the unexpected occur, our worldwide Dealer network is there to help you. Details and contact telephone numbers are shown in the Dealer Directory. In the UK and specific countries within Europe, a special additional emergency service, known as '**Aston Martin Emergency Assistance**', has been designed to provide you and your passengers with the help you need quickly and efficiently should your vehicle suffer a Breakdown Incident ¹.

Vehicles Covered

The benefits of Aston Martin Emergency Assistance are applicable to new and / or used Aston Martin vehicles purchased from an authorised Aston Martin Dealer in one of the following countries; Austria, Belgium, Croatia, Czech Republic, Denmark, France, Germany, Italy, Netherlands, Norway, Portugal, Russia, Spain, Sweden, Switzerland and the UK.

At completion of your purchase, your Aston Martin Dealer will register your vehicle for Aston Martin Emergency Assistance. From registration, your vehicle will be entitled to Aston Martin Emergency Assistance (the '**Vehicle**'). For more details of what constitutes an eligible Vehicle, please refer to the Schedule.

An eligible Vehicle is entitled to receive Aston Martin Emergency Assistance for a period of 36 months from the date of registration with the service provider. Owners of eligible Vehicles can also obtain Aston Martin Emergency Assistance when travelling temporarily outside their Country ², within Europe.

Europe is defined as:

Andorra, Austria, Belgium, Bosnia-Herzegovina, Bulgaria, Crete, Croatia, Czech Republic, Denmark, Estonia, Finland, France, Germany, Gibraltar, Greece, Hungary, Italy, Latvia, Liechtenstein, Lithuania, Luxembourg, Monaco, Netherlands, Norway, Poland, Portugal (not Madeira), Republic of Ireland, Romania, Russia, San Marino, Slovakia, Slovenia, Spain (including the Balearic Islands and Canary Islands), Sweden, Switzerland, Turkey (European Part), Ukraine, and Vatican City.

United Kingdom (UK) is defined as:

England, Scotland, Wales, Northern Ireland, Channel Islands and Isle of Man.

¹ A **Breakdown Incident** means an event where an eligible Vehicle is immobilised due to a breakdown in circumstances where it qualifies for Aston Martin Emergency Assistance, including home-starts, fire, broken glass, accident, theft or vandalism. Furthermore, Aston Martin Emergency Assistance covers you in the event of safety-related defects, which render the Vehicle illegal to drive. These defects relate to, for example, failure of the seat belts, windscreen wipers, direction indicators, front and rear lamps.

² '**Country**' means the country in which your Vehicle is registered.

Benefits

The service provider, appointed by Aston Martin to provide the Aston Martin Emergency Assistance services (the 'Service Provider') will provide the following benefits dependent on requirements to entitled Vehicles in both the home Country and Europe as defined.

Roadside Assistance

The Service Provider's Patrol vehicle should promptly arrive with you after your call has been placed. You may also book an appointment for a convenient time.

Aston Martin Emergency Assistance shall provide you with updates on its estimated time of arrival via your preferred communication method.

If following a Breakdown Incident in an area of coverage, your journey cannot be completed, and where the Vehicle cannot be repaired at the roadside, Aston Martin Emergency Assistance shall organise recovery of the Vehicle, including any luggage contained in the Vehicle at the time. Your Vehicle and luggage shall be transported to the nearest Aston Martin Dealer, without distance or financial limitation.

If the Vehicle cannot be repaired at the roadside or at your home address within a reasonable time period (45 minutes), the Service Provider will take you, the Vehicle and your passengers to the nearest Aston Martin Dealer. In the event that you (or your passengers) need to keep an important appointment, you will be taken there before the disabled Vehicle is transported to its required destination.

Should the Breakdown Incident occur outside of workshop hours, Aston Martin Emergency Assistance shall arrange for secure storage of the Vehicle until the next working day. The Vehicle shall arrive at the Dealer on the next working day, within two hours of the Dealership opening.

If the nearest Dealer, to where the eligible Vehicle has been towed, is able to carry out the repairs at its premises, then the Vehicle will be repaired there.

Once the Vehicle is at a Dealership for repair, Aston Martin Emergency Assistance will keep in contact with the Dealer to follow the progress of the repair, and if necessary, arrange any extension of a replacement vehicle with Aston Martin Customer Service.

Home Start

Aston Martin Emergency Assistance will provide all the benefits of Roadside Assistance at the Vehicle's registered address.

Recovery

If Aston Martin Emergency Assistance cannot repair your Vehicle at the roadside, the Service Provider will arrange recovery of you and your Vehicle to the nearest Aston Martin Dealer.

If your Vehicle has been involved in an accident and has gone off the road and needs to be salvaged before towing, Aston Martin Emergency Assistance will charge you for services on a 'Pay for Use' basis and you may be able to claim these back from your insurance company.

You will be covered for costs of recovery and towing (including any handling fee) but you may be charged for any costs incurred if the Vehicle is, for example, disabled by floods or snow-affected roads, is embedded in sand or mud, or is not easily accessible.

Relay Plus

If your Vehicle cannot be repaired and / or recovery is initiated to an Aston Martin Dealer, the Service Provider will provide alternative travel options for you. You will be entitled to receive one of the following additional services:

a) A replacement vehicle for up to two working days in your Country, or 14 days if the Breakdown Incident occurs outside your Country (a collection and delivery service, or equivalent, is available from chosen suppliers subject to availability and supplier's terms and conditions);

b) Onward transportation; or

c) Overnight accommodation.

Vehicle Collection Following Repair

Following repairs organised by Aston Martin Emergency Assistance, the cost of a first class rail ticket or (if rail transport would normally exceed six hours) a business class air ticket will be met to permit you or a person you designate to collect the repaired Vehicle.

Alternatively, arrangements can be made for your Vehicle to be returned to your home or business address, whichever is the nearest to the repairing Dealer. Alternative addresses closer to the repairing Dealer may also be considered.

Alternative Travel Arrangements

If the Service Provider estimates that the repairs to your Vehicle will take more than eight hours, the Aston Martin Emergency Assistance will cover your reasonable costs for alternative necessary travel, including for members of your party.

Reasonable additional expenses shall be covered for one or a combination of the following:

- Replacement vehicle costs to a maximum of two working days in your Country and up to 14 days outside your Country
- Air fares (business class ticket)
- Rail fares (first class ticket)
- Local taxi fares
- Any other transport equivalent to first class rail fares

Replacement Vehicle

If following a Breakdown Incident:

- Your Vehicle is immobilised
- Roadside repairs are unsuccessful
- If repair of the Vehicle is not possible within the same day after towing to the Dealer

Aston Martin Emergency Assistance will organise free of charge, a replacement vehicle for you until completion of the repairs. The replacement vehicle will include fully comprehensive insurance ¹, with an option to upgrade to include collision damage waiver.

The loan of this replacement vehicle will not exceed two working days (in your Country) or, if the Breakdown Incident occurred outside your Country, 14 days plus two working days after your return to your home country.

Aston Martin Emergency Assistance aim to make sure that the replacement vehicle is a suitable vehicle for you. A priority for the choice of the replacement vehicle is a hire car of category G or equivalent, where available. Specially adapted replacement vehicles will not be provided.

The replacement vehicle will be delivered to you, where possible, but if you prefer, taxi costs for collecting the replacement vehicle, will be met by Aston Martin Emergency Assistance.

¹ Unless the driver is under 21 years of age, where there may be an additional charge incurred.

You will be responsible for fuelling and basic maintenance of the replacement vehicle, whilst under their care. You will also be responsible for paying any deposit required by the vehicle Hire Company.

Once the repair on your Vehicle is complete, the replacement vehicle will then either be returned to the vehicle Hire Company or collection will be arranged where possible, at your request.

If the replacement vehicle has been kept beyond the term of the permitted loan period (as noted above), you will be responsible for any additional charges incurred for the extended period. If you cannot fulfil the nominated vehicle Hire terms and conditions, or circumstances prevent you from qualifying to hire the vehicle, and alternative mobility arrangements are more appropriate, then onward travel arrangements or hotel accommodation will be provided instead. The vehicle hire agreement will be between you and the relevant supplier and will be subject to that supplier's Terms and Conditions. These will usually require or include (amongst other things):

- Production of a full driving licence valid at the time of issue of the hire vehicle
- Limits on acceptable endorsements

- Limitations on the availability and, or engine capacity of the replacement vehicle
- A deposit, e.g. for fuel
- Drivers to be aged at least 18 or 21 years depending on Country, and to have held a full driving licence for at least 12 months.

Onward or Home Journey

If following a Breakdown Incident that occurs more than 80 km from your place of residence, your Vehicle cannot be repaired at the roadside on the same day of the Breakdown Incident, Aston Martin Emergency Assistance will cover:

- The costs of the journey from the place of the Breakdown Incident to the nearest Dealer
- The costs of a replacement vehicle as outlined above
- Where necessary, taxi costs for one journey to the nearest accessible train station or airport, for you and your passenger(s)
- Where necessary, the costs of a first class train journey for you and your passenger(s). If the train journey exceeds six hours, the cost of a scheduled flight (Business Class) for you and your passenger(s).

Aston Martin Emergency Assistance will reimburse you for reasonable costs incurred relating to the above, upon receipt of a claim letter from you, detailing the circumstances of the claim, along with receipts for all transport costs claimed. All claim letters must be directed to Aston Martin Emergency Assistance at The AA, Relay Plus Claims, Aston Martin Emergency Assistance, Fanum House, Basingstoke, Hampshire RG21 4EA, United Kingdom. Only costs directly connected with the Breakdown Incident will be covered.

The refund process to you shall be managed by Aston Martin Emergency Assistance.

Repaired Vehicle Re-delivery

Aston Martin Emergency Assistance will attempt to contact you within 24 hours of successful repair at the Dealer in order to arrange re-delivery of the repaired Vehicle to either your home or place of work, as you request. Alternative addresses closer to the Repairing Dealer may also be considered.

Hotel

If following a Breakdown Incident that occurs more than 80 km from your place of residence, and your Vehicle cannot be repaired at the roadside on the day of the Breakdown Incident, accommodation costs for you and your passenger(s) shall be covered for the duration of the repair, for up to a maximum of two nights if the Breakdown Incident occurs in your Country, or seven nights if the Breakdown Incident occurs outside your Country. You shall be responsible for any excess costs.

Repatriation of Un-repaired Vehicle from Abroad

If the Vehicle cannot be repaired by Aston Martin Emergency Assistance within an agreed time schedule (three working days), the costs for transporting the Vehicle and its contents from the Dealer to the home Country Dealer, will be covered by Aston Martin Emergency Assistance.

Aston Martin Emergency Assistance shall arrange the safe repatriation of the Vehicle at the least cost, whilst respecting the need to deliver the Vehicle to the home Dealer within ten consecutive days.

Aston Martin Emergency Assistance will cover the costs for parking the Vehicle, pending repatriation or import. It maybe necessary for Aston Martin Emergency Assistance to repatriate a caravan or trailer on tow at the time of the Breakdown Incident together with the Vehicle if the Vehicle cannot be repaired abroad by your return date.

What To Do In An Emergency

Should assistance be required in the unlikely event of a Breakdown Incident, simply contact Aston Martin Emergency Assistance using the relevant telephone number listed below. It is important that you call the appropriate number should you require assistance.

 *It may be helpful to have the relevant telephone numbers entered into your telephone 'phone book'.*

UK: 0800 316 1178 ¹

Europe: 00 800 28 86 28 86 ¹.

Europe: 00 33 472 172 508

Please do not make your own arrangements as Aston Martin Emergency Assistance will be not be able to reimburse you. If you are in a remote location and need assistance, the time taken to receive the assistance may be longer because of distance and local restrictions.

Vehicle Identification and Location

To minimise delay, please have the following information available:

¹. Calls from landlines shall be free. Calls from mobile phones will be charged at standard mobile network rates.

European Autoroute Restrictions

- Your name
- Aston Martin model
- The Vehicle Identification Number (VIN). The last six digits from the VIN label stamped into the floor pan under the right-hand front seat
- The location of the vehicle
- Vehicle registration number and colour
- Telephone number where you can be contacted
- Description of the concern experienced

If assistance is required on a French Autoroute or on certain Autoroutes in other European countries, you must use the official SOS boxes at the side of the road in order to arrange initial assistance or recovery. You will be connected to the authorised Autoroute Assistance Service because these roads are privatised. Neither Aston Martin Emergency Assistance nor any other assistance organisations are allowed to assist on these roads.

Once your Aston Martin has been recovered from the Autoroute, you should contact Aston Martin Emergency Assistance at the earliest opportunity to make sure that any further assistance arrangements you require can be made on your behalf.

Aston Martin Emergency Assistance will advise you how to reclaim costs incurred for recovery from the Autoroute.

What is not Covered

Aston Martin Emergency Assistance is thorough and comprehensive; however, claims cannot be met as a result of any of the following:

1. Where you, or anyone else acting on your behalf, make repair or service arrangements without authorisation (and a file number) from Aston Martin Emergency Assistance.
2. Where any loss, theft, damage, death, bodily injury, cost or expense that is not directly associated with the incident that caused you to claim, unless expressly stated in this policy
3. If the Breakdown Incident is due to fire, theft, accident or vandalism, your costs will not be covered by Aston Martin Emergency Assistance but should be met by third party insurance covering the incident.
4. Damage or injury intentionally caused by you or resulting from your participation in a criminal offence.
5. If your Vehicle is kept in an un-roadworthy condition or has not been serviced in accordance with the Manufacturer's recommendations.

6. Any costs that would have been payable by you, such as petrol, toll charges, parking fees, cost of meals, drinks, telephone calls and/ or newspapers or any other costs not specifically stated as being covered by Aston Martin Emergency Assistance, which may be incurred by you and/ or the other member(s) of your party as a result of and/ or in connection with the Breakdown Incident.
7. Release fees: Should your Vehicle be stolen and subsequently recovered by the police, you may be asked to pay a release fee before we can remove your Vehicle to an authorised Aston Martin Dealer.
8. Specialist charges: In the event that the use of specialist equipment is required to give assistance when your Vehicle has, for example, gone off the road, is in a ditch, is standing on soft ground, sand, shingle, stuck in water or snow or has been immobilised by the removal of its wheels, we will arrange recovery but you will be responsible for the costs of any specialist equipment required. The costs may be refundable under the terms of your motor insurance policy.
9. Adverse weather conditions: On those occasions when we experience adverse weather conditions, such as high winds, snow, floods, etc., external resources may be stretched and some operations become physically impossible until the weather improves. At such times, our priority is to make sure that you and your passengers are taken to a place of safety and so the recovery of your Vehicle may not be possible until weather conditions permit.
10. Customer induced breakdown incidents are not covered under Aston Martin Emergency Assistance. However, Aston Martin and the Service Provider will, at their sole discretion, assist you if you request it. However we are not obligated to provide assistance and you shall be responsible for any charges resulting from any assistance given caused by a customer induced fault. In such circumstances, a swipe card deposit maybe taken by the Service Provider. Assistance in such circumstances will not include additional benefits (replacement vehicle, onward journey, hotel accommodation). Customer- induced faults may include, for example, the following:
 - Lock-outs / lost keys
 - Broken keys
 - Discharged battery
 - Running out or loss of fuel
 - Use of wrong fuel (no replacement at the location of breakdown, only towing)
 - Tyre damage
 - Road traffic accidents
11. Lockout / lost keys: Whilst we will always try to provide assistance by the most practical method, should you be unable to gain entry to your Vehicle, modern security systems make it extremely difficult for this to be done should spare keys not be available. If a forced entry is required, you will be asked to sign a declaration stating that you have given permission for this to take place and that any costs for resultant damage will be your sole responsibility.
12. Aston Martin Emergency Assistance shall not be required to provide services in the following circumstances:
 - a) in respect of Vehicles not displaying a valid road fund licence;

b)in respect of eligible Vehicles situated on private property (for example garage premises) unless you can establish to the reasonable satisfaction of Aston Martin Emergency Assistance that permission has been given by the relevant owner or occupier;

c)Vehicle servicing or re-assembly where this is required as a result of neglect or unsuccessful work on the Vehicle other than on the part of the Service Provider or its agents;

d)the recovery of any Vehicles bearing trade plates or which Aston Martin Emergency Assistance has reason to believe have just been imported or purchased at auction;

e)the transportation of immobilised Vehicles where Aston Martin Emergency Assistance considers this to be part of a commercial activity;

f)assistance for Vehicles broken down as a result of taking part in any 'Motor Sport Event', including, without limitation, motor racing, rallying, speed or duration tests or practice thereof, trials or time-trials, auto test (other than auto tests performed by the Client using roadworthy, road legal cars on public roads), but excluding 'Concours d'elegance' events, track test days for road-legal Vehicles or rallies held exclusively on open public roads where participants are required to comply with the normal rules of the road (save for Aston Martin organised and controlled track day events);

g)where the police, highways agency and / or other emergency service require that your Vehicle be recovered by a third part

h)where your entitlement to Aston Martin Emergency Assistance lapses or if your Vehicle is no longer considered eligible for Aston Martin Roadside Assistance, the Service Provider may charge you directly for the Services provided. Any such charges will be charged on a 'pay for use' basis and will constitute a direct contract between you and the Service Provider. If it is determined that Aston Martin is at fault for the Vehicle not being recorded as an eligible Vehicle, then Aston Martin shall pay the relevant charges;

l)assistance for routine maintenance and running repairs of the Vehicle such as fixing faulty radios, interior light bulbs and heated rear windows;

j)for transit risk insurance, which Aston Martin Emergency Assistance recommends you take out where a Vehicle is to be repatriated;

k) where locksmiths, body-glass or tyre specialists are required. Aston Martin Emergency Assistance will endeavour to arrange for their assistance on your behalf, however, you will be responsible for the costs of their services. Further, if use of a locksmith or other specialist would, in Aston Martin Emergency Assistance's opinion, mobilise the vehicle, no further service will be given for the breakdown in question

l) the transportation of any animal or pets shall be at the sole discretion of the Service Provider.

13. The Service Provider may charge you directly for:

a) any replacement component, lubricant and / or fuel (the 'Parts') or consumable items supplied (except where Aston Martin has provided or paid for such Parts);

b) any extension of the Services which you are entitled to receive in connection with this Agreement (which shall be performed by the Service Provider (in its absolute discretion) at your request;

c) the use of any specialist lifting or towing assistance needed to recover your Vehicle if your Vehicle has gone off the road, is in a ditch, sunk in soft ground, sand or shingle or when it is stuck in snow or flood water;

d) any additional charges resulting from the failure to carry legal and serviceable spare wheel(s) or tyre(s) in the Vehicle. Aston Martin Emergency Assistance will endeavour to arrange assistance from a third party on your behalf but you will be responsible for the costs of the call out and/ or for any repair;

e) the cost of garage or other labour required to repair the Vehicle, other than that provided by Aston Martin Emergency Assistance at the scene of the Breakdown Incident;

f) any costs of draining or removing fuel, lubricants or other fluids as a result of the introduction of an inappropriate substance;

g) transportation of personal effects, goods, vehicles, boats or other waterborne craft on or in the Vehicle and any trailer or caravan. Aston Martin Emergency Assistance will not consider any claim for loss resulting from damage to / loss of use of these items. Such items remain your responsibility at all times.

14. If following a Breakdown Incident, the Service Provider, its third party garage agent or subcontractor makes a temporary repair to your Vehicle (for these purposes, a temporary repair shall mean temporary repairs of the Vehicle where the underlying cause of the Vehicle's failure is not resolved), then the Service Provider, its third party garage agent or subcontractor shall recommend you to have such temporary repair made good by a Dealer.

Schedule - Eligible Vehicles

New Vehicles

Any Aston Martin vehicle which is sold directly by Aston Martin or a Dealer in the UK or European Territories and which is first registered in the UK or European Territories (as appropriate).

Used Vehicles

Those used vehicles registered in the UK or the European Territories in respect of which an Extended Warranty has been started.

In All Cases

- Maximum Gross Vehicle Weight (including any caravans or trailers being towed at the time of the Breakdown Incident): 3500 Kg
- Maximum Vehicle Length: 5.5 m
- Maximum Vehicle Width (including any caravans or trailers being towed at the time of the Breakdown Incident): 2.3 m
- Maximum Vehicle Height: 3 m

The dimensions detailed above will be calculated taking into account anything attached to the relevant eligible Vehicle at the time of the relevant Breakdown Incident and any trailer or caravan, including but not limited to towing equipment, any carriers or racks (e.g. bike or luggage), or anything else attached to the Vehicle or the carriers / racks.

Vehicles must be built to manufacturer's specifications, display a road fund licence, and where applicable, hold a certificate of roadworthiness.



ASTON MARTIN



ASTON MARTIN



ASTON MARTIN



ASTON MARTIN

Aston Martin Warranty

Vehicle Warranty	C.2	Consumer Law	C.6
Anti Perforation Corrosion Protection Warranty	C.2	Owner Details	C.7
Period of Cover	C.2	Vehicle Details	C.7
Who May Repair the Vehicle.....	C.3	Owner Warranty Transfer (3).....	C.9
Wear and Tear Items.....	C.3	Owner Warranty Transfer (2).....	C.9
What is Not Covered.....	C.4	Owner Warranty Transfer (1).....	C.9
Customer Responsibility	C.5	Owner Warranty Transfer (6).....	C.11
Warranty Coverage when Touring.....	C.6	Owner Warranty Transfer (5).....	C.11
Aston Martin Extended Warranty.....	C.6	Owner Warranty Transfer (4).....	C.11

Vehicle Warranty

Aston Martin gives a Warranty for each new Aston Martin motorcar and each replacement vehicle or assembly manufactured or supplied by the Company to be free from defects in material and workmanship under normal use and service for the applicable Warranty period.

 *Tyres are covered separately by the tyre manufacturer. Dealers are expected to offer assistance to the customer in pursuing a claim against the tyre manufacturer.*

Exchange Parts Under Warranty

New parts will only be used for repairs at PDI and during the first three months or 5000 km (which ever occurs first) from the date the vehicle is handed over to the first retail customer. Thereafter exchange parts must be used where available under Aston Martin's exchange plan.

Anti Perforation Corrosion Protection Warranty

The vehicle's bodywork is protected by an Anti Perforation Corrosion Warranty. Should any part of the bodywork of the Aston Martin motorcar be perforated, the panel(s) affected by the perforation will be repaired or replaced.

The term 'perforation' means a hole that penetrates through a body panel from the inside.

Period of Cover

The period of cover for all types of warranty commences on the day the vehicle is handed over to the first retail customer.

The Vehicle Warranty period of cover is three years with unlimited mileage.

The Anti Perforation Corrosion Warranty period of cover is ten years with unlimited mileage.

Who May Repair the Vehicle

Franchise holders or Approved Repairers, who are appointed and receive full technical support from Aston Martin, provide facilities for the servicing and repair of Aston Martin motorcars. Only such Franchise Holders or Approved Repairs will under the terms of this warranty, repair replace or readjust, free of charge to the owner, any part or assemble proved to Aston Martins satisfaction to show a defect in materials or workmanship within the applicable period.

Wear and Tear Items

Items that are subject to wear and tear are generally divided into two categories, namely those specified for replacement or adjustment during scheduled maintenance and those that require replacement or adjustment dependent upon conditions of use.

Scheduled Maintenance Items

The items listed below are covered by the Vehicle Warranty up to the first scheduled change point that replacement or adjustment is required during scheduled maintenance operations.

- Drive Belts
- Spark Plugs
- Oil, air, pollen and fuel filters

 *The period of warranty cover for any item may not exceed the time and distance limitation of the vehicle warranty.*

Wear and Tear Items

The items listed below are recognised as having a limited service life or are subject to wear or damage. However, these items are covered by the vehicle warranty for up to one year or the first service, whichever ever occurs first.

- Wiper Blades
- All Light bulbs
HID headlamp bulbs and instrumentation illumination bulbs are covered by the full vehicle warranty.
- Wheel alignment and balancing
- Adjustments, including but not limited to: headlamp and hinged panel adjustments, suspension tightening, steering geometry adjustments, emission and fuel systems checks and handbrake cable adjustments
- Remote handset batteries

 *Brake pads, brake discs and other friction related components are not covered when replacement is due to wear and tear, but they are covered against manufacturing defects for the duration of the Vehicle Warranty.*

Consumables

Replacement or top up of consumable fluids, e.g. oils, antifreeze, brake fluid, windscreen wash solution and refrigerant, is only covered when they are used as part of a warranty repair.

What is Not Covered

Vehicle Warranty

Aston Martin is **not** responsible for any repair or replacement that is required as a direct result of:

- Normal wear and tear
- Failure to properly maintain the vehicle in accordance with Aston Martin's maintenance schedules and service instructions
- Failure to use Aston Martin specified parts or fluids during a warranty repair (or parts of equivalent quality during a retail repair)
- Damage resulting from neglect, accident, flooding or improper use
- Any modification of the vehicle or parts which is not authorised by Aston Martin, including any engine performance enhancement modifications
- Refilling or topping up with incorrect fuel, e.g. diesel instead of petrol
- Use of bio ethanol alternative fuels
- Defects caused as a result of the vehicle being used in motor sport or track events or for any other purpose other than normal private or commercial use

- Any vehicle that has had its vehicle identification number altered or removed, or on which the odometer reading has been unlawfully altered

Paint Surface and Corrosion Protection

Aston Martin is not responsible for any repair or replacement that is required as a direct result of the following:

- Failure to properly maintain paint and bodywork by regular cleaning in accordance with Aston Martin instructions
- Factors beyond Aston Martin's control, such as environmental hazards (including industrial fallout, storm damage, acid rain) and damage (including stone chips, scratches and use of unsuitable cleaning agents)
- Accident repairs using materials or methods of repair that have not been approved by Aston Martin
- Alterations of the vehicle from Aston Martin's original specification
- Failure to rectify on a timely basis any paint or corrosion damage as recorded in the vehicle documentation by a dealer at the time of the annual inspection

Customer Responsibility

Other Exclusions

The Aston Martin warranty excludes liability for any lost time, inconvenience, loss of transportation, or any other incidental or consequential damage you (or anyone else) may incur as a result of a defect covered by this warranty.

The customer literature will describe the proper care and use of the vehicle. Proper maintenance and use guard against major repair expenses resulting from misuse, neglect or inadequate maintenance, and may help increase the value that the customer may receive when selling the vehicle.

The Customer is responsible to:

- Make sure that the vehicle is maintained in accordance with the vehicle service and maintenance guide published in the customer literature
Failure to perform maintenance promptly and in accordance with Aston Martins specified service intervals will invalidate warranty coverage on the parts affected
- The customer is required to take the vehicle to a dealer for any warranty repairs as soon as practicable after a defect is detected

- Make sure that the Service and Maintenance schedule has been stamped by the servicing dealer after the completion of a scheduled service operation
- Make sure that paint and bodywork is maintained by regular cleaning in accordance with the vehicle manufacturer's instructions
- Make sure that the body panels are examined annually by an authorised Aston Martin Dealer and that this inspection is recorded in the Owners Guide

Warranty Coverage when Touring

Aston Martin has a comprehensive service network in most parts of the world. Any authorised Aston Martin Dealer can carry out repairs under the terms of the vehicle warranty. Under normal circumstances, the customer should not be required to pay for any warranty work performed by an Aston Martin Dealer.

It is the customer's responsibility to produce the warranty documentation issued with the new vehicle. This establishes the customer's right to warranty coverage and the relevant maintenance and service records. If the customer is unable to do so, the dealer should seek advice from Aston Martin.

Aston Martin Extended Warranty

Aston Martin Extended Warranty is specifically designed to provide the customer with first class after-sales protection from unexpected repair costs when the vehicle warranty has expired, and the knowledge that your Aston Martin will be repaired by trained technicians using only genuine Aston Martin parts.

Contact your Aston Martin Dealer for more information on the benefits and protection provided by the Aston Martin Extended Warranty.

Consumer Law

The Aston Martin warranties are manufacturers' warranties that supplement and do not affect your legal rights under the vehicle purchase agreement with your selling dealer or under applicable national legislation governing the sale of consumer goods.

Owner Details

Name:

Address:

:

:

Post Code:

Signature:

Date:

(Dealer Stamp)

Vehicle Details

Registration Plate No.:

VIN No.:

Engine No.:

Warranty Start Date:

If the vehicle is sold, the benefits of any unexpired portion of the warranties can be transferred to the new owner.

The new owner should complete a 'tear off' sheet (next page) and send the new details to:

Aston Martin Warranty Department

Aston Martin Lagonda Limited

Banbury Road,

Gaydon,

WARWICK

Warwickshire,

CV35 0DB,

England



ASTON MARTIN



ASTON MARTIN



ASTON MARTIN



ASTON MARTIN

Owner Warranty Transfer (3)**Registration plate No.:****VIN No.:****Recorded mileage (km / mile):****Date of Purchase:****Name:****Address:**

:

:

:

Post Code:**Telephone No.:****Signature:****Date:****Owner Warranty Transfer (2)****Registration plate No.:****VIN No.:****Recorded mileage (km / mile):****Date of Purchase:****Name:****Address:**

:

:

:

Post Code:**Telephone No.:****Signature:****Date:****Owner Warranty Transfer (1)****Registration plate No.:****VIN No.:****Recorded mileage (km / mile):****Date of Purchase:****Name:****Address:**

:

:

:

Post Code:**Telephone No.:****Signature:****Date:**



ASTON MARTIN



ASTON MARTIN



ASTON MARTIN

Owner Warranty Transfer (6)**Registration plate No.:****VIN No.:****Recorded mileage (km / mile):****Date of Purchase:****Name:****Address:**

:

:

:

Post Code:**Telephone No.:****Signature:****Date:****Owner Warranty Transfer (5)****Registration plate No.:****VIN No.:****Recorded mileage (km / mile):****Date of Purchase:****Name:****Address:**

:

:

:

Post Code:**Telephone No.:****Signature:****Date:****Owner Warranty Transfer (4)****Registration plate No.:****VIN No.:****Recorded mileage (km / mile):****Date of Purchase:****Name:****Address:**

:

:

:

Post Code:**Telephone No.:****Signature:****Date:**



ASTON MARTIN



ASTON MARTIN



ASTON MARTIN

Alphabetical Index

A

Accessory Power Socket	3.23
Airbags	3.12
Passenger Deactivation Switch	3.15
Alarm	2.6
Anti Corrosion Inspection	A.8
Anti-Lock Braking System	5.6
Aston Martin Assistance	B.1
Aston Martin Warranty	C.1
Audio	7.1
Essentials	7.2
Automatic Transmission	5.4

B

Battery	
Maintenance	10.25
Battery Charge	10.25
Battery Disposal	10.24
Bonnet Release	10.6
Brake Pad 'Bedding-in'	10.12

Brakes

Anti-Lock Braking System	5.6
--------------------------------	-----

C

Cabin Storage	3.21
Catalytic Converters	5.12
Child Seats	3.18
Passenger Airbag Deactivation	3.15
Climate Control	
Automatic Operation	6.6
Controls	6.2
Manual Operation	6.6
Operating Tips	6.2
Condensation, Headlamp Units	10.33

Controls

Information and Warning Symbols	4.3
Instrument Cluster	4.3
Stalk	4.11

D

Dangerous Substances	10.4
Data Recording	1.5
Defrosting and Demisting	
Automatic	6.6
Manual	6.7
Driving Techniques	5.13

E

Electric Windows	3.24
------------------------	------

F

Fluid Levels	10.8
Footbrake	5.6
Fuel	
Catalytic Converters	5.12
Fuel Filling	5.11
Fuse Boxes	10.25

H

Hands-Free Phone	8.1
Connecting a Phone	8.3
Removing a Phone	8.5
Using a Phone	8.5
Headlamp Bulb	10.33
Headlamp Condensation	10.33

I

Interior Mirrors	3.6
Internal Lamps	10.37

J

Jump Start From Another Vehicle	10.22
---------------------------------------	-------

L

Locking the Vehicle	2.4
---------------------------	-----

M

Maintenance	10.1, 10.5
Vehicle Jacking	10.3
Maintenance Items	
Tool Kit	10.6

D.2

Manual Transmission	5.5
Master Vehicle Lock	2.4
Mirrors	
Door	3.7
Interior	3.6
Power Fold Function (Door Mirrors)	3.7

P

Park Brake	5.7
Passive Anti-Theft System	2.6

R

Replacement of Airbag Units Record	A.10
Replacement of Seat Belt Pre-tensioners Record	A.10
Restraints System	3.8
Determining if the System is Operational	3.8

S

Safety Defects - Reporting	1.5
Satellite Navigation	9.1
Map Updates	9.3
Software Updates	9.3
System Controls	9.4
Seat Adjustment	3.2
Seat Belts	3.8
Care and Maintenance	10.40
Child	3.11
Seats	
Temperature Controlled	3.5
Servicing	A.4
Specifications	11.1
Steering Wheel	3.6
Supplemental Restraints System	3.12

T

Tailgate	2.5
Temperature Controlled Seats	3.5
Trip	4.6
Tyre Sealant Kit	10.14

U

Unlocking the Vehicle 2.3

V

Vehicle Battery 10.23

Vehicle Horn 4.13

Vehicle Identification 1.4

Vehicle Key 2.2

Vehicle Recovery 10.20

Vehicle Stability Control 5.8

Vehicle Storage 10.40

W

Wheel Nut Torque 11.4

Window Reset 10.37

Windscreen Blade Replacement 10.11

Wipers

 Wiper 4.12



ASTON MARTIN



ASTON MARTIN



ASTON MARTIN



ASTON MARTIN



ASTON MARTIN